

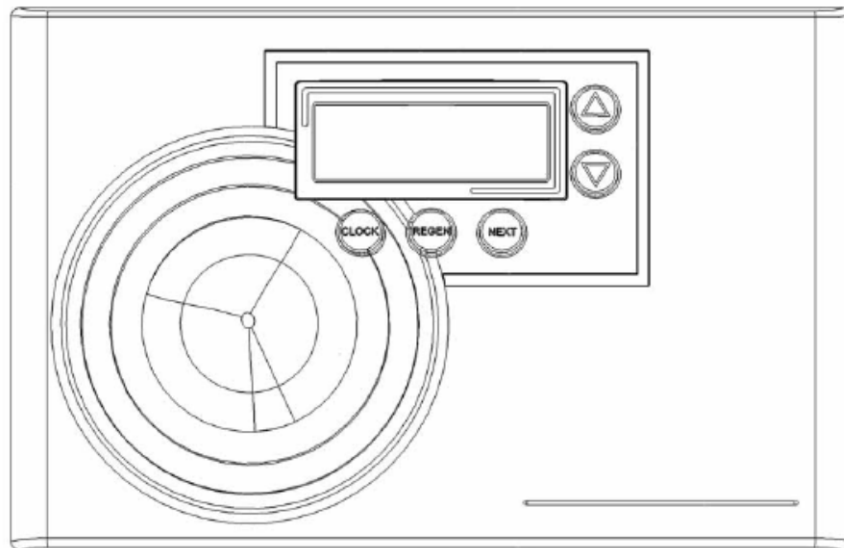

# MASTER

*Water Conditioning Corp.*

## Installation and Operation Manual



---

### MP-MCA Top Mount Water Softeners with MCA100 Control Valve

---

July 2014 Version

## Table of Contents

Page No.	Topic	Description
1	Performance Data Sheet	MP-MCA-30T
2	Performance Data Sheet	MP-MCA-45T
3	Performance Data Sheet	MP-MCA-60T
4	Model # and Packaging	Packaging Information
	Component Packaging Description	Packaging Description
5	Certification	NSF/ANSI 44 Information
	Softening System	System Positioning
6	MP-MCA Control Valve	Attaching Valve to Tank
	MP-MCA Control Valve	Attaching Valve, cont'd
7	Service & Drain Piping	Drain Piping
8	Service & Drain Piping, cont'd	Drain Piping
9	System Schematic	Piping Layout
10	Electrical Supply	Electrical Requirements
	Brine Tank / Brine Tubing	Brine tank w/shut off
11	Filling Softener with Water	Details for Filling Softener Tank with Water
12	MP-MCA-Control Valve Timer	Setting the timer
13	Final Check	Final Installation Check
	Disinfection	Conditioner Disinfection
14	Manual Regeneration	Instructions for Manual Regeneration
	Power loss/ Error codes	"What if" Instructions
15	Bypass	Bypass Operation
16	Troubleshooting	Problem/ Cause / Solution
17	Troubleshooting	Problem/ Cause / Solution
18	Troubleshooting	Problem/ Cause / Solution
19	Error Code Troubleshooting	Problem/ Cause / Solution
20	Error Code Troubleshooting, cont'd	Problem/ Cause / Solution, cont'd
21	Valve Parts List	Part Numbers List
22	Valve Parts List	Part Numbers List
23	Valve Parts List	Part Numbers List
24	Valve Parts List	Part Numbers List
25	Valve Parts List	Part Numbers List
26	Valve Parts List	Part Numbers List
27	Valve Parts List	Part Numbers List
28	Warranty	Warranty

## Performance Data Sheet

<b>Model Number</b>	<b>MP-MCA-30T</b>
Rated Service Flow (gpm)	17.8
Pressure Drop at Rated Service Flow Rate (psi)	15
Rated Softening Capacity (KGrains)	18.8 @ 4.5 lbs salt 20.0 @ 6.0 lbs salt 28.9 @ 15.0 lbs salt
Efficiency at the 1.0 lb. Salt setting (Grains/lbs salt)	4186
Min.-Max. Working Pressure (psi)	20 to 100
Min.-Max. Operating Temperature (°F)	35 to 100
Max. Flow Rate (gpm) to Drain During Regeneration Cycle	1.7
Amount of High Capacity Resin (cu ft)	1.0

These softeners conform to NSF/ANSI 44 for the specific performance claims as verified and substantiated by test data. These models are efficiency rated. The efficiency rating is valid only at the stated salt dose and maximum service flow rate. They have a demand initiated regeneration (D.I.R.) feature that complies with specific performance specifications intended to minimize the amount of regenerant brine and water used in their operation. These softeners have a rated softener efficiency of not less than 3350 grains of total hardness exchange per pound of salt (based on sodium chloride) and shall not deliver more salt than their listed ratings. The rated salt efficiency is measured by laboratory tests described in NSF/ANSI Standard 44. These tests represent the maximum possible efficiency that the systems can achieve. Operational efficiency is the actual efficiency after the system has been installed. It is typically less than the efficiency due to individual application factors including water hardness, water usage, and other contaminants that reduce the softener's capacity. These systems are not intended for use with water that is microbiologically unsafe or of unknown quality without adequate disinfection before or after the system. Refer to Installation/operation manual and warranty for further details on installation, parts and service, maintenance and further restrictions or limitations to the use of the product.

Master Water Conditioning  
224 Shoemaker Rd.  
Pottstown, PA 19464  
610.323.8358  
610.323.5526  
www.masterwater.com



## Performance Data Sheet

<b>Model Number</b>	<b>MP-MCA-45T</b>
Rated Service Flow (gpm)	15.4
Pressure Drop at Rated Service Flow Rate (psi)	15
Rated Softening Capacity (KGrains)	28.3 @ 6.75 lbs salt 30.0 @ 9.0 lbs salt 43.4 @ 22.5 lbs salt
Efficiency at the 1.0 lb. Salt setting (Grains/lbs salt)	4186
Min.-Max. Working Pressure (psi)	20 to 100
Min.-Max. Operating Temperature (°F)	35 to 100
Max. Flow Rate (gpm) to Drain During Regeneration Cycle	1.7
Amount of High Capacity Resin (cu ft)	1.5

These softeners conform to NSF/ANSI 44 for the specific performance claims as verified and substantiated by test data. These models are efficiency rated. The efficiency rating is valid only at the stated salt dose and maximum service flow rate. They have a demand initiated regeneration (D.I.R.) feature that complies with specific performance specifications intended to minimize the amount of regenerant brine and water used in their operation. These softeners have a rated softener efficiency of not less than 3350 grains of total hardness exchange per pound of salt (based on sodium chloride) and shall not deliver more salt than their listed ratings. The rated salt efficiency is measured by laboratory tests described in NSF/ANSI Standard 44. These tests represent the maximum possible efficiency that the systems can achieve. Operational efficiency is the actual efficiency after the system has been installed. It is typically less than the efficiency due to individual application factors including water hardness, water usage, and other contaminants that reduce the softener's capacity. These systems are not intended for use with water that is microbiologically unsafe or of unknown quality without adequate disinfection before or after the system. Refer to Installation/operation manual and warranty for further details on installation, parts and service, maintenance and further restrictions or limitations to the use of the product.

Master Water Conditioning  
224 Shoemaker Rd.  
Pottstown, PA 19464  
610.323.8358  
610.323.5526  
www.masterwater.com



## Performance Data Sheet

<b>Model Number</b>	<b>MP-MCA-60T</b>
Rated Service Flow (gpm)	18.3
Pressure Drop at Rated Service Flow Rate (psi)	15
Rated Softening Capacity (KGrains)	37.7 @ 9.0 lbs salt 40.0 @ 12.0 lbs salt 57.9 @ 30.0 lbs salt
Efficiency at the 1.0 lb. Salt setting (Grains/lbs salt)	4186
Min.-Max. Working Pressure (psi)	20 to 100
Min.-Max. Operating Temperature (°F)	35 to 100
Max. Flow Rate (gpm) to Drain During Regeneration Cycle	2.7
Amount of High Capacity Resin (cu ft)	2.0

These softeners conform to NSF/ANSI 44 for the specific performance claims as verified and substantiated by test data. These models are efficiency rated. The efficiency rating is valid only at the stated salt dose and maximum service flow rate. They have a demand initiated regeneration (D.I.R.) feature that complies with specific performance specifications intended to minimize the amount of regenerant brine and water used in their operation. These softeners have a rated softener efficiency of not less than 3350 grains of total hardness exchange per pound of salt (based on sodium chloride) and shall not deliver more salt than their listed ratings. The rated salt efficiency is measured by laboratory tests described in NSF/ANSI Standard 44. These tests represent the maximum possible efficiency that the systems can achieve. Operational efficiency is the actual efficiency after the system has been installed. It is typically less than the efficiency due to individual application factors including water hardness, water usage, and other contaminants that reduce the softener's capacity. These systems are not intended for use with water that is microbiologically unsafe or of unknown quality without adequate disinfection before or after the system. Refer to Installation/operation manual and warranty for further details on installation, parts and service, maintenance and further restrictions or limitations to the use of the product.

Master Water Conditioning  
 224 Shoemaker Rd.  
 Pottstown, PA 19464  
 610.323.8358  
 610.323.5526  
[www.masterwater.com](http://www.masterwater.com)



**Installation and Operating Instructions for**  
**MP-MCA CONTROL**  
**Top Mount Water Softener**

**Model #:**

_____	MP-MCA-30T CS *	1.0 CF Crawl Space Water Softener
_____	MP-MCA-30T	1.0 CF Water Softener
_____	MP-MCA-45T	1.5 CF Water Softener
_____	MP-MCA-60T	2.0 CF Water Softener

*\*Not Tested or certified to NSF/ANSI Standard 44*

**Shipping Carton Description / unit:**

# of cartons	Contents	Description
1	Mineral tank	Distributor pipe installed
1	Brine tank	464 shutoff valve assembly. <b>*NOTE:</b> MP-MCA valve is shipped in brine tank.
1	MP-MCA control valve	MP-MCA timer and backwash flow control and bypass with 1" copper or pvc connection
	C-800	Pre-loaded @ factory

**NOTE: THIS SOFTENER IS NOT INTENDED TO BE USED FOR TREATING WATER THAT IS MICROBIOLOGICALLY UNSAFE OR OF UNKNOWN QUALITY WITHOUT ADEQUATE DISINFECTION WHETHER BEFORE OR AFTER THE SYSTEM.**

**NOTE: The model MP-MCA-30T has been tested and certified by the Water Quality Association according to NSF/ANSI 44 for the specific performance claims as verified and substantiated by test data as follows:**



**Rated Efficiency: 4186 Grains per pound of salt**  
**4.5 lbs salt: 18.8 Kg Capacity**  
**6 lbs salt: 20.0 Kg Capacity**  
**15 lbs salt: 28.9 Kg Capacity**  
**Rated Service Flow: 17.8 GPM @ 15 psi pressure drop**  
**Resin: 1.0 Cubic Ft. Cation Exchange resin**

**NOTE: The model MP-MCA-45T has been tested and certified by the Water Quality Association according to NSF/ANSI 44 for the specific performance claims as verified and substantiated by test data as follows:**



**Rated Efficiency: 4186 Grains per pound of salt**  
**6.75 lbs salt: 28.3 Kg Capacity**  
**9 lbs salt: 30.0 Kg Capacity**  
**22.5 lbs salt: 43.4 Kg Capacity**  
**Rated Service Flow: 15.4 GPM @ 15 psi pressure drop**  
**Resin: 1.5 Cubic Ft. Cation Exchange resin**

**NOTE: The model MP-MCA-60T has been tested and certified by the Water Quality Association according to NSF/ANSI 44 for the specific performance claims as verified and substantiated by test data as follows:**



**Rated Efficiency: 4186 Grains per pound of salt**  
**9 lbs salt: 37.7 Kg Capacity**  
**12 lbs salt: 40.0 Kg Capacity**  
**30 lbs salt: 57.9 Kg Capacity**  
**Rated Service Flow: 18.3 GPM @ 15 psi pressure drop**  
**Resin: 2.0 Cubic Ft. Cation Exchange resin**

***Water Softener Positioning:***

1. Place water softener in desired position, far enough from walls and other obstructions to allow for servicing the unit.
2. Place the water softener within reasonable access to a grounded 115V/60 HZ circuit and a legal drain line connection.

### **MP-MCA Control Valve:**

1. When facing the front of the MP-MCA timer, the inlet connection is located on the right and the outlet connection is on the left. The control valve's inlet and outlet connections are either 1" copper or PVC equipped with split ring and nut.

Control Valve

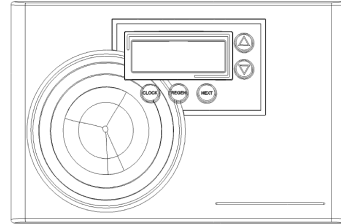

Front View

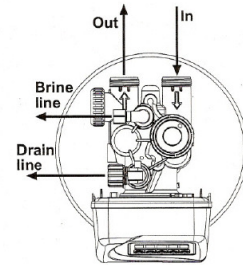

Top View

2. Turn the control valve upside down and ensure that the control valve distributor o'ring is in place. Use silicone lubricant on the o'ring.

**\*\*DO NOT USE PETROLEUM!\*\***

**\*\*USE ONLY SILICONE \*\***

3. Place the control valve onto the distributor pipe and into the tank opening.
4. Thread the control valve hand tight . Do not overtighten.
4. Locate the bypass valve assembly that is packaged with the control valve. The bypass valve has two red handles that indicate flow direction, two threaded connections for the tail piece kit and two o'ring seal connections with nuts for the control valve. Align the insert connection ends with o'ring seals and nuts to the inlet and outlet connections of the control valve. Hand tighten the nuts. **DO NOT OVERTIGHTEN THE NUT!**



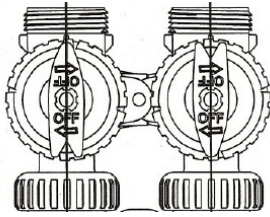

Bypass Valve

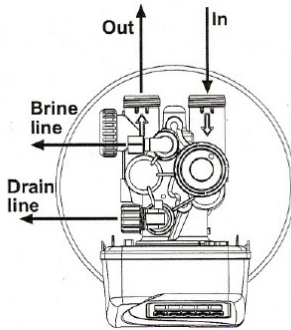

Control Valve

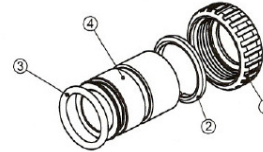

Tail piece assembly

5. Locate the tail piece kit that is packaged with the control valve. The standard tail piece kit is 1" copper with optional 1" / 3/4" PVC or 3/4" copper kits available as a special order. Each tail piece, o'ring, split ring and nut is presassembled at the factory. Align a tail piece assembly to the bypass valve threaded inlet and insert until the nut can be tightened. Hand tighten the nut because excessive tightening will damage the assembly. **REPEAT THE PROCEDURE FOR THE OUTLET CONNECTION.**

### ***Service and Drain Piping:***

1. Pipe water softener into the service lines .The inlet and outlet connections of the control valve are 1" copper or PVC and are located on the back of the valve body. As you face the timer the inlet is on the right and the outlet is on the left. Always follow local plumbing codes when installing our water treatment equipment.
2. If sweat fittings are used, be sure soldering is done in such a manner as not to allow heat to reach the control valve or bypass. (If Schedule 80 PVC is used make sure to follow the proper primer and solvent instructions.)
3. The drain line connection is 5/8" OD or 3/4" npt and is located on the top left of the valve as you face the timer. It is recommended you install a 3/4" union on the drain line for servicing if not using 5/8 OD. The drain line must be of adequate size to allow for full regeneration flow.

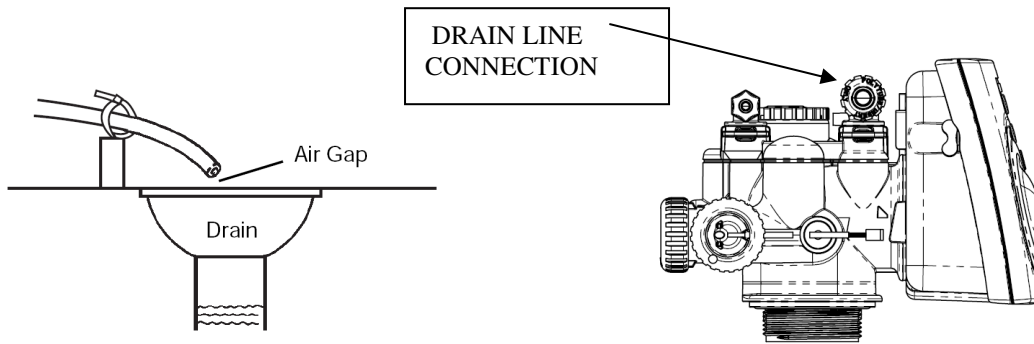

- The control valve drain connection is 3/4" npt.
- Never decrease the drain piping size to below the drain connection size.
- Maximum drain line length is 30 feet with proper sloping the entire length.
- Maximum drain line height is 6 feet above the control valve.
- The drain line must be piped to an open air gap (See Figure above)
- Always follow local plumbing codes.

**UNDER NO CIRCUMSTANCES SHOULD THERE BE A DIRECT CONNECTION WITH SANITARY SEWAGE FACILITIES.**

**NOTE: The drain flow rate during regeneration (backwash) will be:**

<b>MP-MCA-30T</b>	<b>1.7 GPM</b>
<b>MP-MCA-45T</b>	<b>1.7 GPM</b>
<b>MP-MCA-60T</b>	<b>2.7 GPM</b>

**\*NOT TESTED OR CERTIFIED TO NSF/ANSI STANDARD 44**



**MASTER**  
*Water Conditioning Corp.*

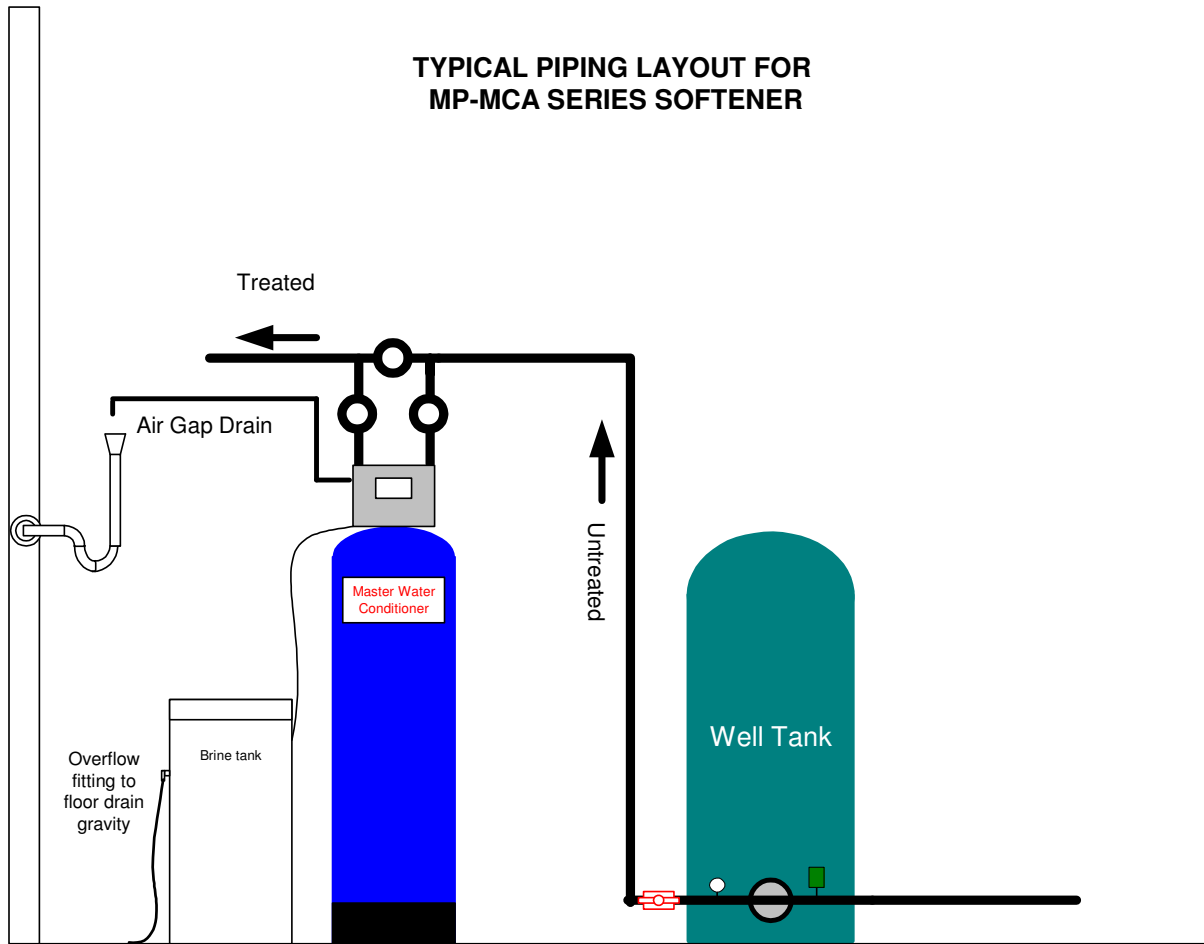

**NOTE:** All Master Water Conditioners must be installed after the well tank or water meter if its public water supply.

**Temperature :**      **MAX: 120 F, MIN: 34F**  
**Pressure: MAX: 100 PSI, MIN: 20 PSI**  
**Electrical: 115V/ 60 HZ**

## **Electrical Requirements:**

Always follow all local electrical codes when installing our water treatment equipment.

1. Provide an 115v/60Hz properly grounded dedicated electrical Outlet. (It's very important that the polarity be correct)  
**Avoid using outlets that are switch controlled.**
2. Maximum amperage required is 5 amps.
3. Make sure the electrical service provides power 24 hours per day.  
We recommend installing a **surge protector** to protect unit from power surges, which are not covered by warranty.

## **Brine Tank:**

1. The brine tank should be located directly beside the water softener mineral tank.
2. Connect the 3/8" poly tubing to the 3/8" black elbow quick-connect fitting located on the top left side of the MCA control valve.

**See Figure Below.**

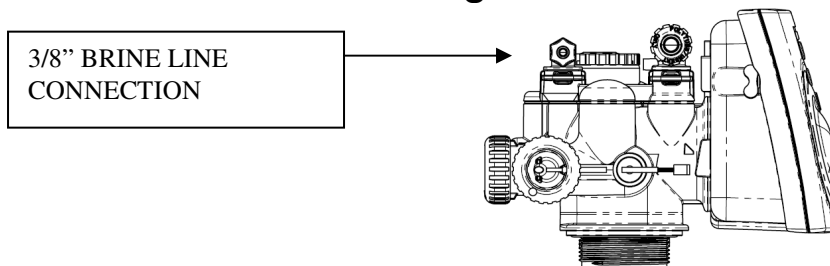

**The brine tank is equipped with a shutoff valve, the float height was preset at the factory.**

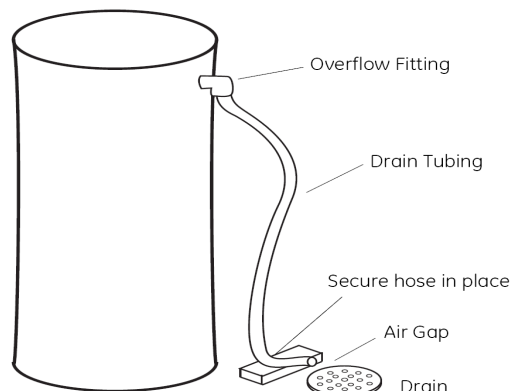

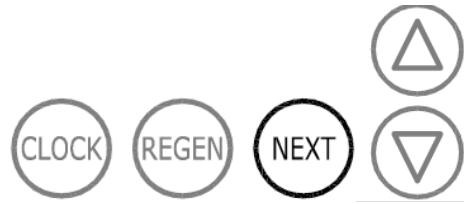

***Filling Water Softener with Water:***

1. Connect the MP-MCA control valve transformer into the electrical outlet provided.
2. Press and hold the REGEN button until the drive motor starts. When the drive motor stops, the display will read “BACKWASH” position.
3. Open the inlet ball valve a ¼ turn of its full open position to allow water to enter the water softener mineral tank slowly. The water is going to enter the tank from the bottom of the distributor pipe and leave the tank from the top. This will slowly purge all the air from the tank.

**IF WATER ENTERS THE TANK TOO FAST, ALL THE CATION RESIN WILL BE FLUSHED TO DRAIN DURING START UP.**

4. When only water is running to the drain, open the inlet and outlet ball valves fully.
5. Press the REGEN again until the drive motor starts. When the drive motor stops, the display will read “BRINE” position.
6. Press the REGEN button until the drive motor starts. When the drive motor stops, the display will read “RINSE” position. The fast rinse position will rinse the softener tank.
7. The control valve will automatically advance to the brine refill position where the brine tank will fill with the proper amount of water. The display will read “REFILL”.

**NOTE: THE TIMER WILL AUTOMATICALLY ADVANCE TO THE SERVICE POSITION AND THE DISPLAY WILL READ THE CAPACITY REMAINING, IN GALLONS.**

## ***MP-MCA Control Valve Timer Settings:***

**Note:** The control valve is set at the factory. You only need to set the time of day , hardness and regeneration time if required, which is preset at 2 am.

### ***Time of Day Setting***

- 1) Press the CLOCK button. The screen will show the Time of Day in blinking numbers.
- 2) To change the Time of Day, use the UP and DOWN arrows to set the Hour.
- 3) To change the Minutes, press the CLOCK button, and use the UP and DOWN arrows to set the Minutes
- 4) Press the CLOCK button.

### ***Hardness Setting (the factory default is 10)***

- 1) Press the NEXT and UP arrow, hold for 3 seconds. The screen will show the Hardness as grains per gallon in blinking numbers.
- 2) To change the number, use the UP or DOWN arrows.
- 3) Press the NEXT button.

**If water was tested by Master Water Conditioning, follow recommendations on water analysis, for hardness setting**

### ***Regeneration Day Override Setting (the factory default is OFF)***

- 1) The screen will show the Regeneration Day Override in blinking numbers.
- 2) To change the number, use the UP or DOWN arrows.
- 3) Press the NEXT button.

### ***Time of Regeneration Setting (the factory default is 2 AM)***

- 1) The screen will show the Time of Regeneration in blinking numbers.
- 2) If Regeneration time change is desired, use the UP or DOWN arrows to set the hour.
- 3) Press the NEXT button, and use the UP or DOWN arrows to set the minutes.
- 4) Press the NEXT button.

**NOTE: SALT SETTING AND CAPACITY ARE PRESET AT THE FACTORY.**

### **Final Check:**

1. Fill the brine tank with Solar Salt and the Res-Up Feeders with Res-Up (one quart is provided).
2. Make sure the drain line connection meets all plumbing codes and that the drain line size can handle the backwash flow rate of the softener.
3. Make sure the Inlet and Outlet on bypass valve are open.
4. Make sure the control valve timer is plugged into an electrical outlet with power 24 hours per day.
5. Check all piping for leaks.

### **Disinfection of Water Conditioners**

The materials of construction of the modern water conditioner will not support bacterial growth, nor will these materials contaminate a water supply. However, the normal conditions existing during shipping, storage and installation indicate the advisability of disinfecting a conditioner after installation, before the conditioner is used to treat potable water. In addition, during normal use, a conditioner may become fouled with organic matter or in some cases with bacteria from the water supply.

Thus every conditioner should be disinfected after installation, some will require periodic disinfection during their normal life, and in a few cases disinfection with every regeneration would be recommended.

Depending upon the conditions of use, the style of conditioner, the type of ion exchanger, and the disinfectant available, a choice can be made among the following methods.

#### **Sodium or Calcium Hypochlorite**

##### **Application**

These materials are satisfactory for use with polystyrene resins, synthetic gel zeolite, greensand and bentonites.

##### **5.25% Sodium Hypochlorite**

These solutions are available under trade names such as Clorox Bleach\*. If stronger solutions are used, such as those sold for commercial laundries, adjust the dosage accordingly.

1. Dosage
  - a. Polystyrene resin: 1.2 fluid ounces per cubic foot.
  - b. Non-resinous exchangers: 0.8 fluid ounce per cubic foot.

\*Clorox is a registered trademark of The Clorox Company.

2. Brine tank conditioners
  - a. Backwash the conditioner and add the required amount of hypochlorite solution to the brine well of the brine tank. (The brine tank should have water in it to permit the solution to be carried into the conditioner.)
  - b. Proceed with the normal regeneration.

#### **Calcium Hypochlorite**

Calcium hypochlorite, 70% available chlorine, is available in several forms including tablets and granules. These solid materials may be used directly without dissolving before use.

1. Dosage
  - a. Two grains (approximately 0.1 ounce) per cubic foot.
2. Brine tank conditioners
  - a. Backwash the conditioner and add the required amount of hypochlorite to the brine well of the brine tank. (The brine tank should have water in it to permit the chlorine solution to be carried into the conditioner.)
  - b. Proceed with the normal regeneration.

## ***Manual Regeneration:***

**Note: For softeners, if brine tank does not contain salt, fill with salt and wait at least 2 hours before regeneration.**

To initiate manual regeneration immediately, press and hold the “REGEN” button for three seconds. The system will begin to regenerate immediately. **The request cannot be cancelled.**

To initiate a manual regeneration at the preset delayed regeneration time, when the regeneration time option is set to “NORMAL” or “NORMAL + on 0”, press and release “REGEN”. The words “REGEN TODAY” will flash on the display to indicate that the system will regenerate at the preset delayed regeneration time. If you pressed “REGEN” in error, pressing the button again will cancel the request.

**Note: If the regeneration time option is set to “on 0” there is no set delayed regeneration time so “REGEN TODAY” will not activate if “REGEN” button is pressed.**

## **Power Loss**

If the power goes out for less than two hours, the system will automatically reset itself. If an extended power outage occurs, the time of day will flash on and off which indicates the time of day should be reset. The system will remember the rest.

## **Error Message**

If the word “ERROR” and a number are alternately flashing on the display, contact a service technician for help. This means the valve is unable to function properly. ( See page 21 )



# BYPASS VALVE OPERATION

Figure 1

## NORMAL OPERATION

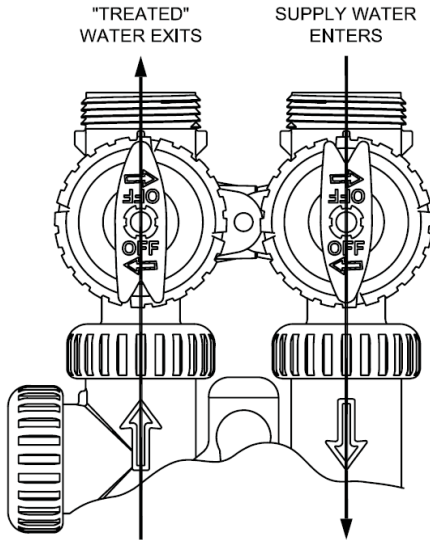

Figure 2

## BYPASS OPERATION

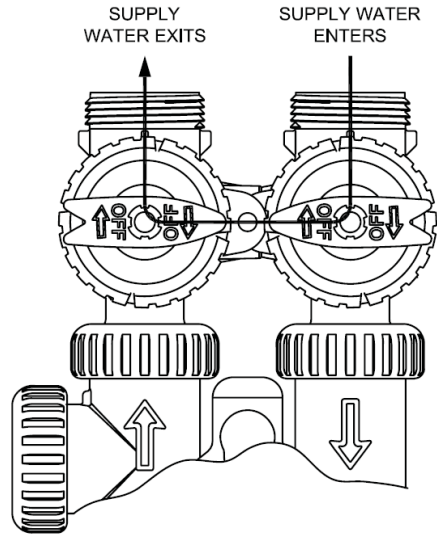

Figure 3

## DIAGNOSTIC MODE

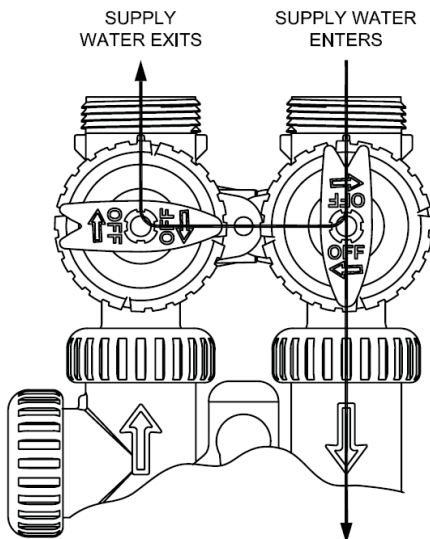
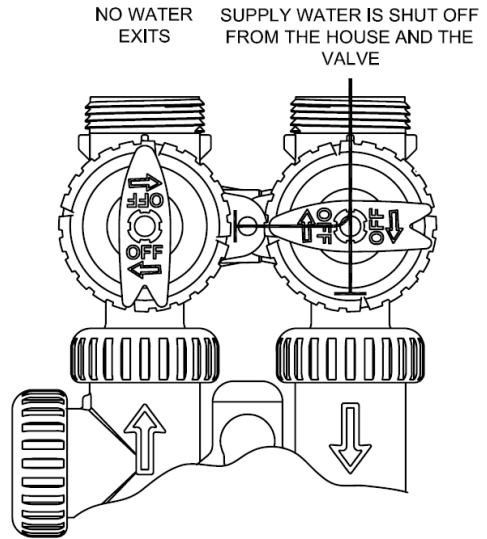

Figure 4

## SHUT OFF MODE



## Troubleshooting

**Symptom:** Water conditioner fails to regenerate.

<b>Possible Cause</b>	<b>Solution</b>
Power supply to MP-MCA125 control has been interrupted.	Determine reason for power interruption and correct. Reset time of day.
Water pressure lost	Restore water pressure.
Control valve has incorrect program values.	Reset values.
Meter clogged	Remove meter and clean.
Defective control.	Replace control assembly.
No Solar Salt in brine tank	Add Solar Salt, wait 4 hours and regenerate.
Insufficient Solar Salt	Check brine float height and clean assembly if necessary. Check flow rate capabilities of safety float and air check assembly.
Manual bypass valve is open.	Close manual bypass valve.
Leak at riser pipe seal	Insure that riser pipe is properly sealed at o'ring seal. Inspect pipe for cracks.
Plugged injector or injector screen	Inspect and clean injector and/or injector screen.

**Symptom:** No Brine Draw

<b>Possible Cause</b>	<b>Solution</b>
Plugged injector or injector screen	Inspect and clean injector and/or injector screen.
Insufficient water pressure	Increase water pressure above 25 psig (172kPa) minimum.
Obstructed drain line	Remove obstruction.

**Symptom:** Insufficient Brine draw

<b>Possible Cause</b>	<b>Solution</b>
Partially clogged injector or injector screen	Inspect and clean injector and/or injector screen assembly.
Restricted flow rate in brine line	Check flow rate capabilities of the safety float/aircheck assembly.
Insufficient water pressure	Increase water pressure above 25 psig (172kPa) minimum.
Excessive back pressure on injector due to elevated drain line	Reduce drain line elevation to height of valve.
Damaged piston assembly	Inspect and if damaged replace the piston assembly.
Control valve has incorrect program values.	Reset values.
Partially restricted drain line	Remove restriction.

**Symptom:** Insufficient Refill to Brine Tank

<b>Possible Cause</b>	<b>Solution</b>
Control valve has incorrect program values.	Reset values.
Restricted flow rate in brine line	Check flow rate capabilities of the safety float/aircheck assembly.

**Problem:** Leak to Drain

<b>Possible Cause</b>	<b>Solution</b>
No flow control installed in drain line.	Install drain line flow control.
Insufficient water pressure.	Increase water pressure above 25 psig (172kPa) minimum.

**Symptom:** Excessive Water in Brine Tank

<b>Possible Cause</b>	<b>Solution</b>
Plugged drain line flow control	Clean flow control.
Control valve has incorrect program values.	Reset values.
Plugged injector and/or injector screen	Inspect and clean injector and/or screen.

**Symptom:** Loss of Media to Drain

<b>Possible Cause</b>	<b>Solution</b>
No flow control installed in drain line	Install drain line flow control.

**Symptom:** Loss of Water Pressure

<b>Possible Cause</b>	<b>Solution</b>
Fouled softener media bed due to iron accumulation or chlorine.	Replace media bed.
Slots in riser pipe or laterals are filled with softener media fines.	Inspect and clean distributor pipe slots as needed.

**Symptom:** Brine in Water to Service After Regeneration

<b>Possible Cause</b>	<b>Solution</b>
Injector is too small for system size.	Install correct injector.
Plugged injector and/or injector screen	Inspect and clean injector and/or injector screen.
Brine draw time excessively long due to low water pressure	Increase water pressure above 25 psig (172 kPa) minimum.
Restricted drain line	Remove drain line restriction.
Insufficient rinse volume	Increase slow rinse time, fast rinse time, or both.
Damaged piston assembly or spacer kit	Inspect and if damaged replace the piston assembly.
Control valve has incorrect program values.	Reset values.

# ERROR CODES

## ERROR DESCRIPTIONS

(V3890MP-02 BOARD with 5800.0 Software)

101	UNABLE TO START. Control not sensing valve movement with motor output energized.
102	#1 MAV/Stager #1 MOTOR STALLED. Unable to find proper park position.
103	#1 MAV/Stager #1 MOTOR RAN TOO LONG. Unable to find proper park position.
104	#1 MAV/Stager #1 VALVE HOMING. Control unable to find the HOME position of the valve
106	#2 MAV/Stager #2 MOTOR RAN TOO LONG. Unable to find proper park position.
107	#2 MAV/Stager #2 MOTOR STALLED. Unable to find proper park position.
109	INVALID MOTOR STATE Control can no longer operate due to the detection of an invalid motor state.
116	#3 MAV/Stager #3 MOTOR RAN TOO LONG. Unable to find proper park position.
117	#3 MAV/Stager #3 MOTOR STALLED. Unable to find proper park position.
126	#4 MAV/Stager #4 MOTOR RAN TOO LONG. Unable to find proper park position.
127	#4 MAV/Stager #4 MOTOR STALLED. Unable to find proper park position.
201	INVALID REGEN STEP Control can no longer operate due to the detection of an invalid regeneration cycle step (Internal software error)
402	POWER DOWN MEMORY Control can no longer operate due to a <u>check sum error</u> for the operational data and status section memory
403	PROGRAM MEMORY Control can no longer operate due to a <u>check sum error</u> for the programming section memory
404	DIAGNOSTIC MEMORY Control can no longer operate due to a <u>check sum error</u> for the diagnostic section memory
405	HISTORY MEMORY Control can no longer operate due to a <u>check sum error</u> for the history section memory
406	CONTACT MEMORY Control can no longer operate due to a <u>check sum error</u> for the contact screen section memory.

- 407 STATUS RAM MEMORY FAILURE Control can no longer operate due to corrupted data detected in the operational and status section. Once generated the error mode is not entered nor an error display viewed.  
Instead previous (<6 hours) data is used
- 408 DIAGNOSTIC RAM MEMORY FAILURE Control can no longer operate due to corrupted data detected in the diagnostic section. Once generated, the error mode is not entered nor an error display viewed.  
Instead previous (<6 hours) data is used.
- 410 CONFIG DOWNLOAD Configurator file downloaded to the control was not originally uploaded from another control with the identical software.

### Refill Flow Control Assembly and Refill Port Plug

Drawing No.	Order No.	Description	Quantity
1	V3195-01	WS1 Refill Port Plug Asy	This part is required for backwash only systems
2	H4615	Elbow Locking Clip	1
3	H4628	Elbow 3/8" Liquifit	1
4	V3163	O-ring 019	1
5	V3165-01*	WS1 RFC Retainer Asy (0.5 gpm)	1
6	V3182	WS1 RFC	1
7	V4144-01	Elbow 3/8 Liquifit Asy w/RFC	1
Not Shown	V3552	WS1 Brine Elbow Asy w/RFC	Option
Not Shown	H4650	Elbow 1/2" with nut and insert	Option

\*Assembly includes V3182 WS1 (0.5 gpm) RFC.

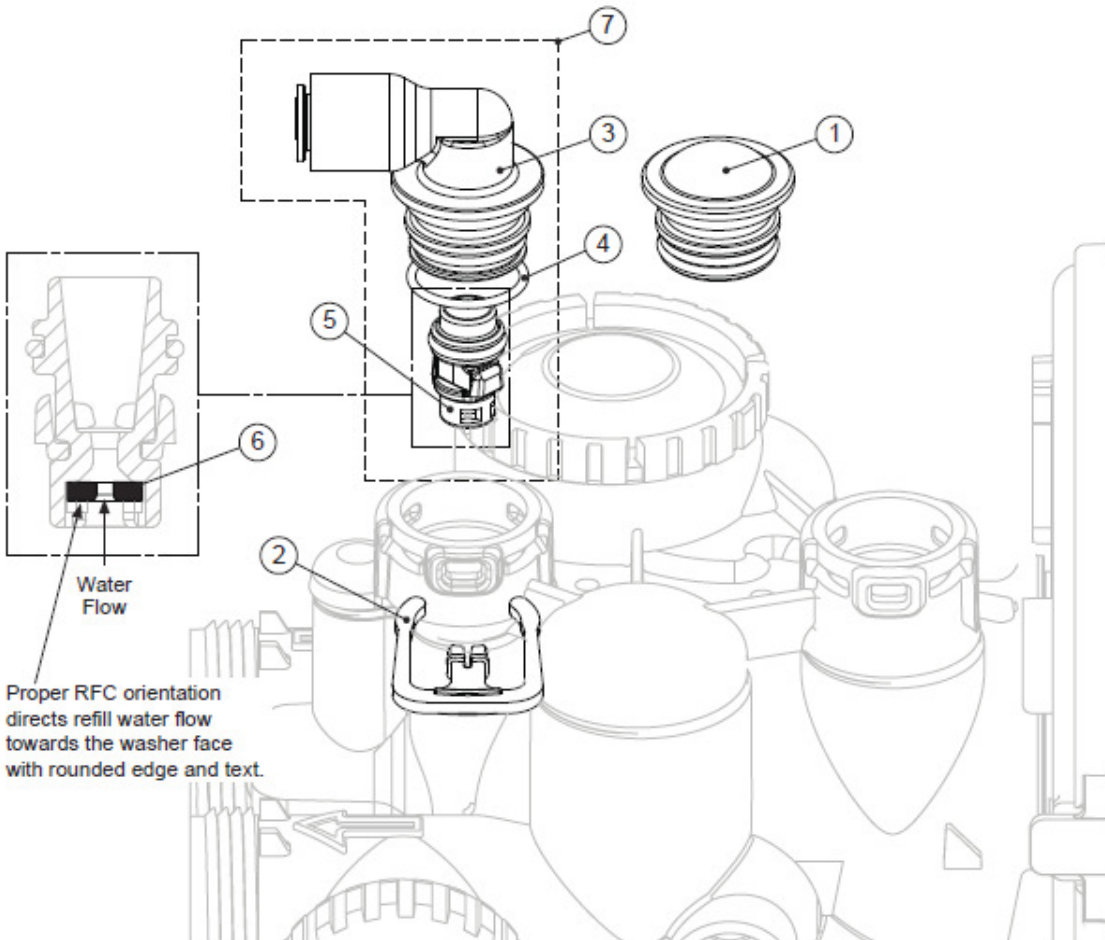

**Injector Cap, Injector Screen, Injector, Plug and O-Ring**

Drawing No.	Order No.	Description	Quantity
1	V3176	INJECTOR CAP	1
2	V3152	O-RING 135	1
3	V3177-01	INJECTOR SCREEN CAGE	1
4	V3010-1Z	WS1 INJECTOR ASY Z PLUG	1
5	V3010-1A	WS1 INJECTOR ASY A BLACK	1
	V3010-1B	WS1 INJECTOR ASY B BROWN	
	V3010-1C	WS1 INJECTOR ASY C VIOLET	
	V3010-1D	WS1 INJECTOR ASY D RED	
	V3010-1E	WS1 INJECTOR ASY E WHITE	
	V3010-1F	WS1 INJECTOR ASY F BLUE	
	V3010-1G	WS1 INJECTOR ASY G YELLOW	
	V3010-1H	WS1 INJECTOR ASY H GREEN	
	V3010-1I	WS1 INJECTOR ASY I ORANGE	
	V3010-1J	WS1 INJECTOR ASY J LIGHT BLUE	
V3010-1K	WS1 INJECTOR ASY K LIGHT GREEN		
Not Shown	V3170	O-RING 011	*
Not Shown	V3171	O-RING 013	*

\* The injector plug and the injector each contain one 011 (lower) and 013 (upper) o-ring.

Note: For upflow position, injector is located in the up hole and injector plug is in the other hole.

WS1 and WS1.25 upflow bodies are identified by having the DN marking removed.

Upflow option is not applicable to EE, EI, or TC control valves.

For a filter that only backwashes, injector plugs are located in both holes.

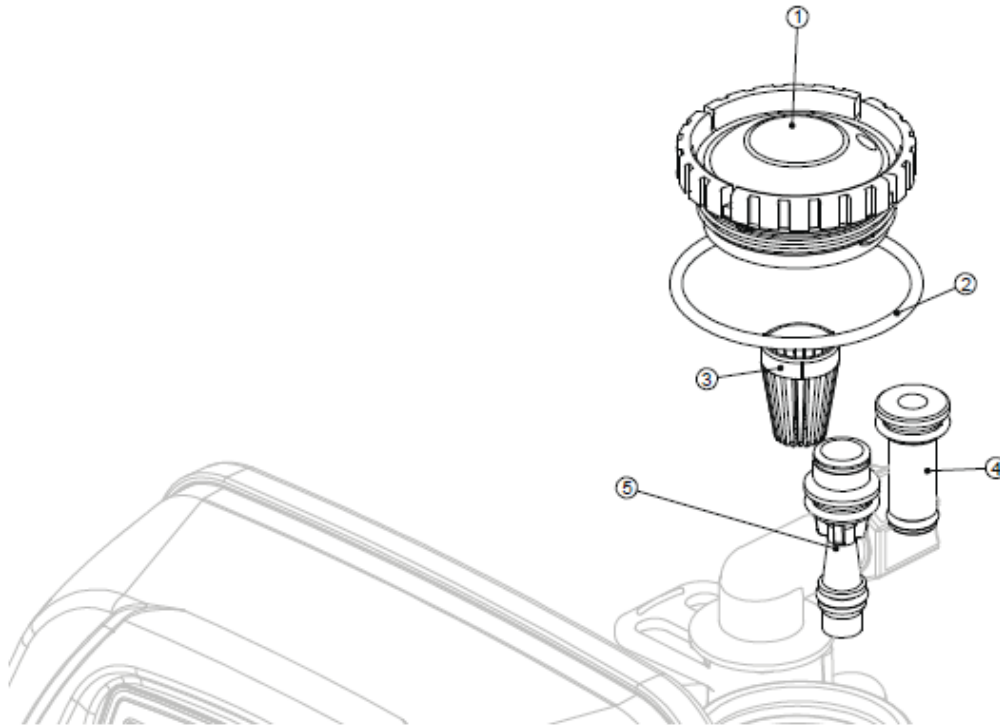



### Drain Line – 3/4"

Drawing No.	Order No.	Description	Quantity
1	H4615	Elbow Locking Clip	1
2	PKP10TS8-BULK	Polytube insert 5/8	Option
3	V3192	WS1 Nut 3/4 Drain Elbow	Option
4*	V3158-01	WS1 Drain Elbow 3/4 Male	1
5	V3163	O-ring 019	1
6*	V3159-01	WS1 DLFC Retainer ASY	1
7	V3162-007	WS1 DLFC 0.7 gpm for 3/4	One DLFC must be used if 3/4 fitting is used
	V3162-010	WS1 DLFC 1.0 gpm for 3/4	
	V3162-013	WS1 DLFC 1.3 gpm for 3/4	
	V3162-017	WS1 DLFC 1.7 gpm for 3/4	
	V3162-022	WS1 DLFC 2.2 gpm for 3/4	
	V3162-027	WS1 DLFC 2.7 gpm for 3/4	
	V3162-032	WS1 DLFC 3.2 gpm for 3/4	
	V3162-042	WS1 DLFC 4.2 gpm for 3/4	
	V3162-053	WS1 DLFC 5.3 gpm for 3/4	
	V3162-065	WS1 DLFC 6.5 gpm for 3/4	
	V3162-075	WS1 DLFC 7.5 gpm for 3/4	
	V3162-090	WS1 DLFC 9.0 gpm for 3/4	
	V3162-100	WS1 DLFC 10.0 gpm for 3/4	

\*4 and 6 can be ordered as a complete assembly - V3331 WS1 Drain Elbow and Retainer Asy

Valves are shipped without drain line flow control (DLFC) - install DLFC before using. Valves are shipped without 3/4 nut for drain elbow (polytube installation only) and 5/8" polytube insert (polytube installation only).

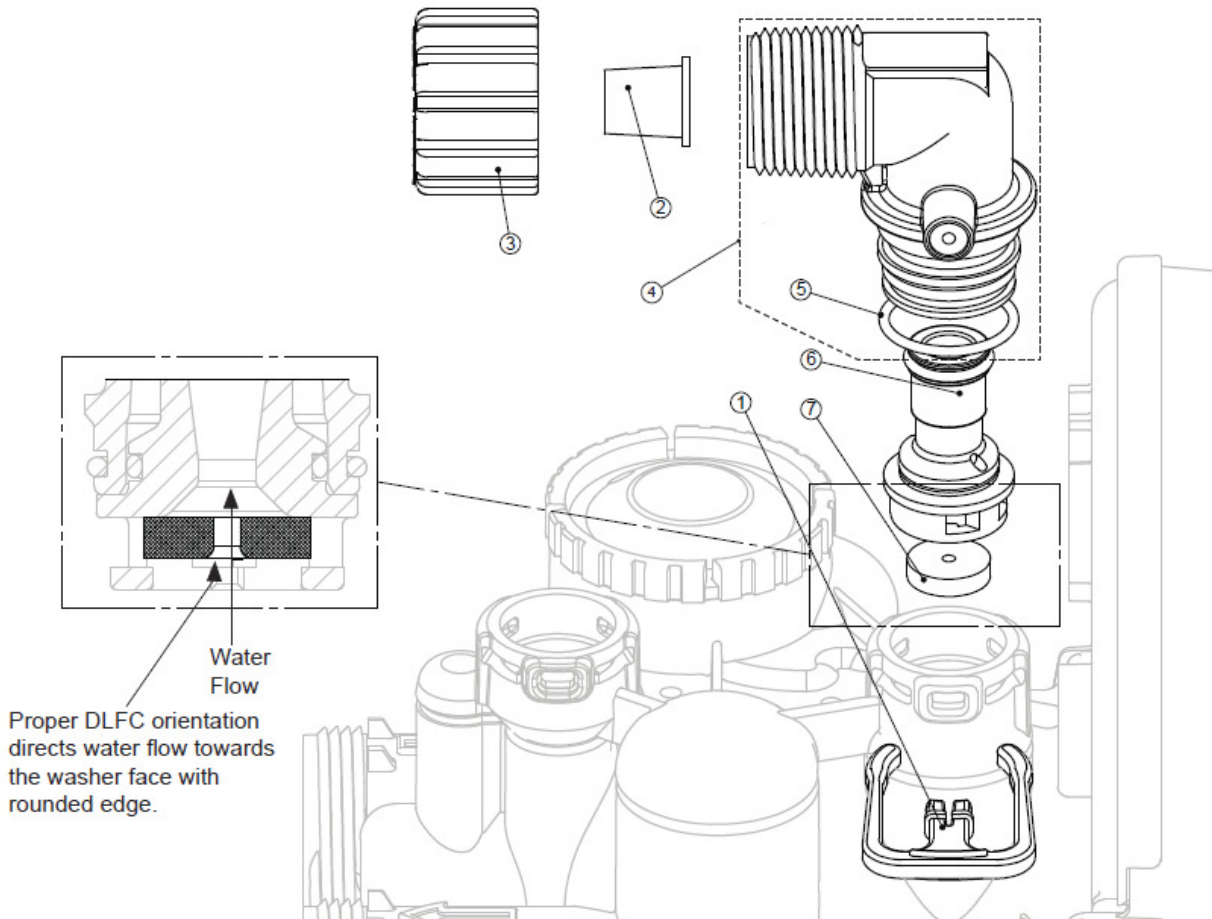

**Water Meter, Meter Plug and Mixing Valve**

Drawing No.	Order No.	Description	Quantity
1	V3151	WS1 Nut 1" QC	1
2	V3003*	WS1 Meter ASY	1
3	V3118-01	WS1 Turbine ASY	1
4	V3105	O-ring 215	1
5	V3003-01	WS1 Meter Plug ASY	1
6	V3013	Mixing Valve	Optional

\*Order number V3003 includes V3118-01 WS1 Turbine ASY and V3105 O-ring

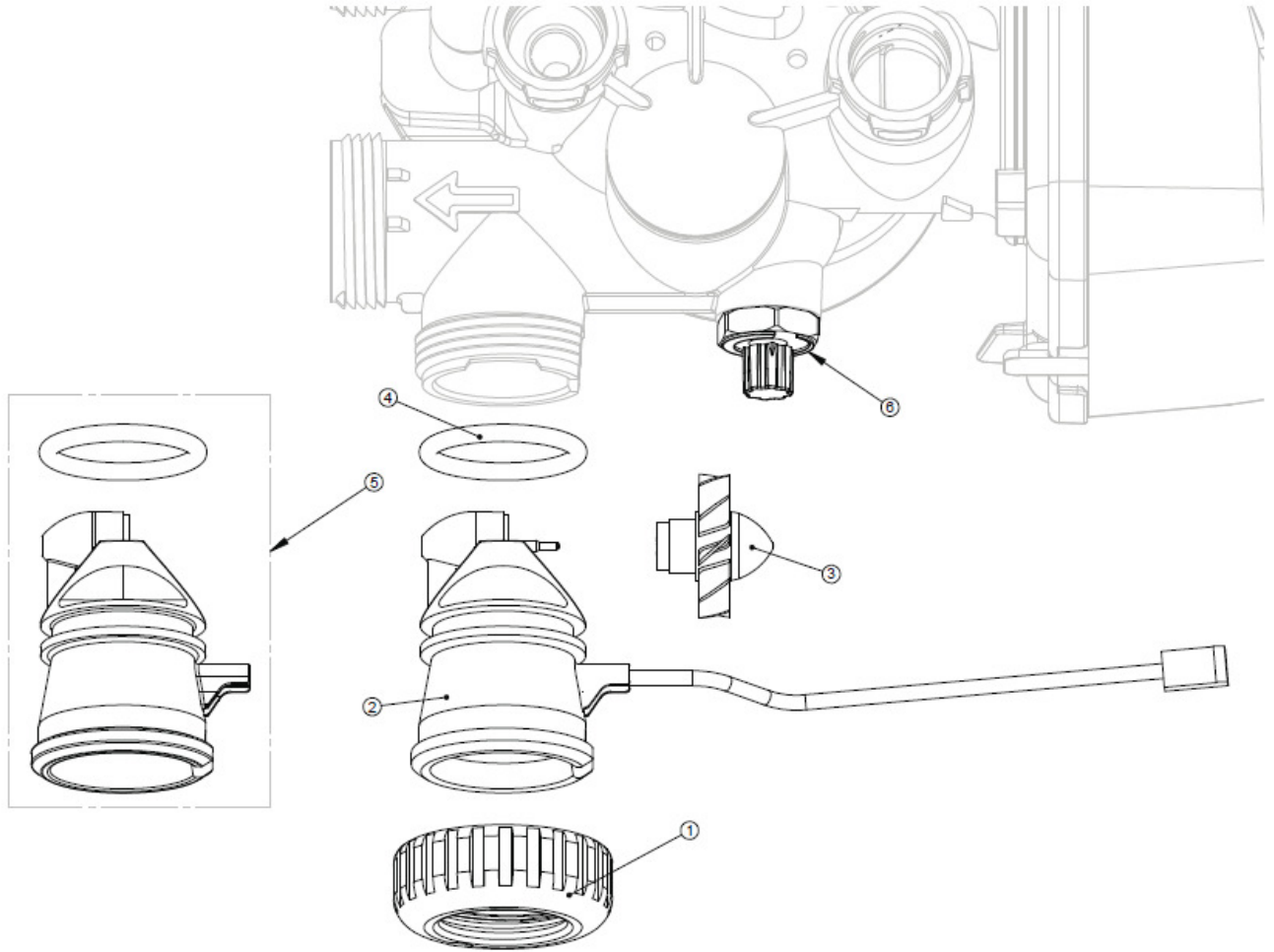

**THIS WATER METER SHOULD NOT BE USED AS THE PRIMARY MONITORING DEVICE FOR CRITICAL HEALTH EFFECT APPLICATIONS.**

**NOTE:** A water meter is not applicable for a TC control valve.

**Bypass Valve**

Drawing No.	Order No.	Description	Quantity
1	V3151	WS1 Nut 1" Quick Connect	2
2	V3150	WS1 Split Ring	2
3	V3105	O-Ring 215	2
4	V3145	WS1 Bypass 1" Rotor	2
5	V3146	WS1 Bypass Cap	2
6	V3147	WS1 Bypass Handle	2
7	V3148	WS1 Bypass Rotor Seal Retainer	2
8	V3152	O-ring 135	2
9	V3155	O-ring 112	2
10	V3156	O-ring 214	2

(Not Shown) Order No. V3191-01, Description: WS1 Bypass Vertical Adapter Assembly

Order No.	Description	Quantity
V3151	WS1 Nut 1" Quick Connect	2
V3150	WS1 Split Ring	2
V3105	O-Ring 215	2
V3191	WS1 Bypass Vertical Adapter	2

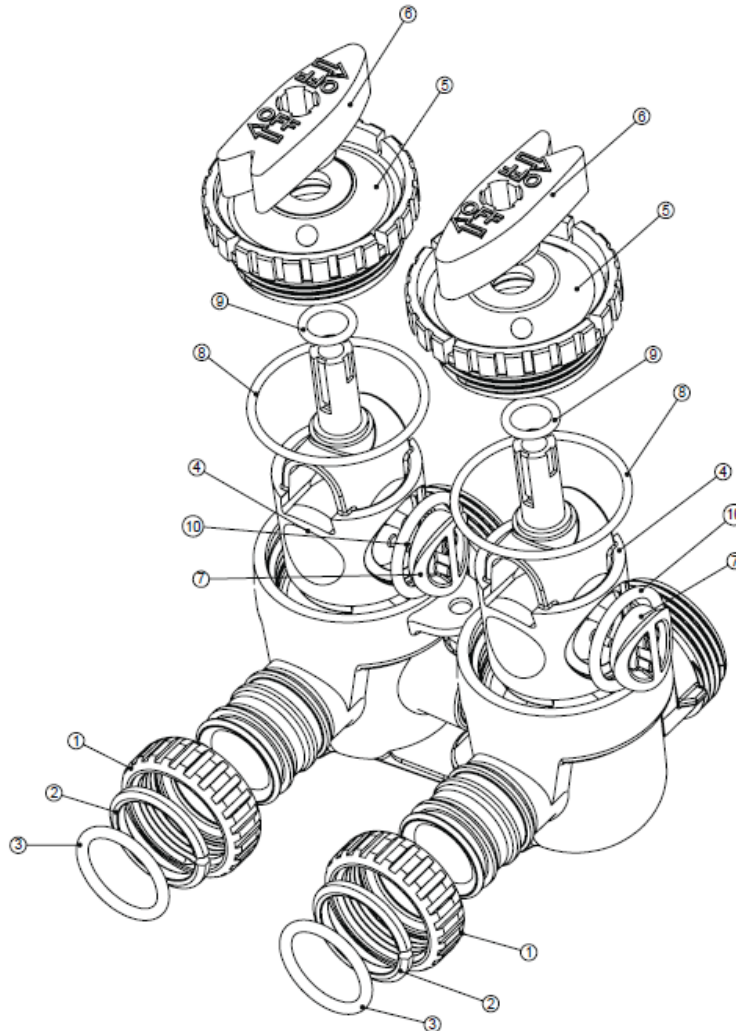

## MP Front Cover and Drive Assembly

Drawing No.	Order No.	Description	Quantity
1	V3371-01	WS1MR FRONT COVER ASSEMBLY	1
2	V3107-01	WS1 MOTOR	1
3	V3106-01	WS1 DRIVE BRACKET & SPRING CLIP	1
4	V3890MP-02BOARD	WS1THRU2L/2 MP PCB XMEGA REPLACE	1
5	V3110	WS1 DRIVE REDUCING GEAR 12X36	3
6	V3109	WS1 DRIVE GEAR COVER	1
NOT SHOWN	V3186	WS1 AC ADAPTER 120V-12V	1
	V3186-01	WS1 AC ADAPTER CORD ONLY	
NOT SHOWN	V3372	WS1MR DRIVE BACK PLATE	1
NOT SHOWN	V3463	WS1MR QUARTER TURN FASTENERS	2
NOT SHOWN	V3466	O-RING 008	2

Refer to Control Valve Service Manual for other drawings and part numbers.

AC Adapter	U.S.
Supply Voltage	120 V AC
Supply Frequency	60 Hz
Output Voltage	12 V AC
Output Current	500 mA

Relay Specifications: 12V DC Relay with a coil resistance not less than 80 ohms. If mounting the relay under the cover check for proper mounting location dimensions on the backplate.

Wiring For Correct On/Off Operation	
PC Board Relay Terminal Block	Relay
RLY 1	Coil -
V +	Coil +
RLY 2	Coil -

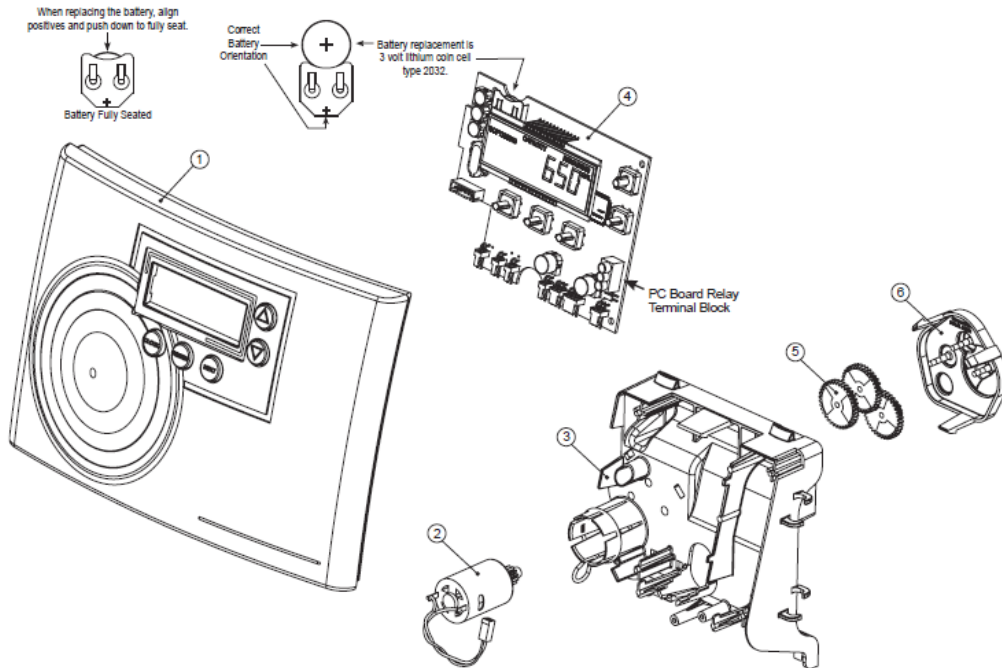

Drawing No.	Order No.	Description	Quantity
1	V3005	WS1 Spacer Stack Assembly	1
2	V3004	Drive Cap ASY	1
3	V3372	WS1MR Drive Back Plate	1
4	V3011	WS1 Piston Downflow ASY	1
5	V3174	WS1 Regenerant Piston	1
6	V3135	O-ring 228	1
7	V3180	O-ring 337	1
8	V3105	O-ring 215 (Distributor Tube)	1
9	V3466	O-ring 008	2
10	V3463	WS1MR Quarter Turn Fasteners	2
Not Shown	V3001	WS1 Body ASY Downflow	1
	V3001-02	WS1 Mixing Valve Body ASY	
	V3001UP	WS1 Body ASY Upflow	
	V3001-02UP	WS1 Mixing Valve Body Upflow ASY	
Not Shown	V3013	WS1 Mixing Valve ASY	1

Note: The regenerant piston is not used in backwash only applications.

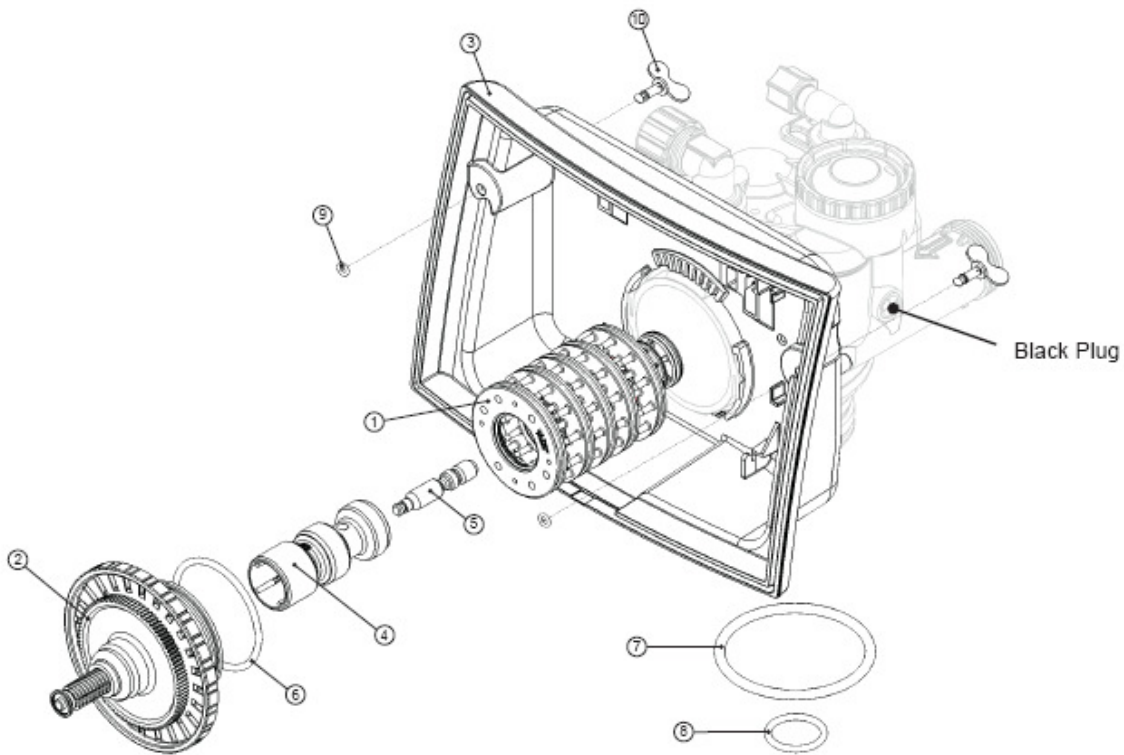

# 12 YEAR LIMITED WARRANTY

As of Oct. 1, 1995

This Residential Water Conditioner is warranted for a period of **one year** from date of purchase by first user against defects in materials and workmanship. In addition, the complete control valve is warranted for **five years**. The control valve body (excluding internals and electrical parts) is warranted for **six years**. The mineral tank, plastic brine tank or cabinet tank (excluding mineral) is warranted against rust, corrosion or bursting for a period of **twelve years** from date of manufacture. Except, as specifically set forth in this paragraph, Master Water Conditioning Corporation makes no other warranties, express or implied.

This warranty shall be void if the conditioner is moved from the place of original installation, or if damage is caused by misuse, misapplication, accident, freezing, flood, fire or if not installed in accordance with instructions furnished by Master Water Conditioning Corporation.

This warranty shall be void in the event of damages from external sources or where the conditioner has been operated at pressure in excess of 100 pounds per square inch or at a temperature greater than 100 degrees F. or less than 32 degrees F. Incidental costs or consequential damages are not covered by this warranty.

All defective parts shall be returned prepaid to Master Water Conditioning Corporation for inspection. **Master shall not be liable for labor charges other than Master factory repairs.**

This warranty gives you specific legal rights, and you may have other rights which vary from state to state. Some states do not allow limitations on duration of implied warranties or exclusion of incidental or consequential damages, so the above limitations may not apply to you.

All claims must be submitted in writing to Master Water Conditioning Corporation at 224 Shoemaker Road, Pottstown, Pennsylvania 19464 within thirty (30) days from the discovery of the defect. Master Water Conditioning Corporation thereafter will correct defective parts and workmanship or rusting, corrosion or bursting within sixty (60) days.



224 Shoemaker Rd. Pottstown, Pa. 19464