

Puro ® *Drinking Water System*

MODEL PURO-35T

INSTALLATION, OPERATION & SERVICE MANUAL



This drinking water system is tested and Certified to ANSI/NSF Standard 58 for the reduction of: Barium, Cadmium, Chromium (Hexavalent), Chromium (Trivalent), Copper, Cyst, Fluoride, Lead, Mercury, Nitrate, Nitrite, Radium 226/228, Selenium, TDS, and Turbidity as verified and substantiated by test data.

TABLE OF CONTENTS

	Page
SECTION I. INTRODUCTION	1
SECTION II. SPECIFICATIONS	2
SECTION III. PREPARATION	3
A. Major System Components	3
B. Tools Recommended for Installation	5
C. Site Selection For Major System Components	5
SECTION IV. INSTALLATION STEPS	6
A. Faucet with Water Quality Monitor Installation	6
B. Feed Water Saddle Valve Installation	8
C. Drain Clamp Installation	9
D. R.O. Manifold Assembly Installation	10
E. Position the Drinking Water Holding Tank and Make the Final Hose Connections	11
F. Start Up	11
SECTION V. OPERATION AND MAINTENTANCE	12
A. Normal Operation	12
B. Changing Filters	13
C. Changing the In-Line Activated Carbon Post Filter	14
SECTION VI. TECHNICAL DATA	14
A. Water Quality	14
B. Water Quantity	14
C. Net Pressure Differential	15
D. Water Production Rate Chart	16
SECTION VII. TROUBLE SHOOTING GUIDE	17
EXPLODED VIEW AND PARTS LIST	19

CAUTION:

The Centers for Disease Control and Prevention (CDC) and the Environmental Protection Agency (EPA) have issued guidance to people with severely weakened immune systems who may want to take extra precautions to reduce the risk of infection with *Cryptosporidium* from drinking water. This guidance pertains to people with HIV/AIDS, patients receiving treatment for cancer, recipients of organ or bone marrow transplants, transplant patients taking immunosuppressive drugs, and persons who have congenital immunodeficiencies.

The EPA has stated that they do not know the importance of drinking water compared to other possible sources of *Cryptosporidium* to determine how most people become infected. The CDC-EPA guidance suggest that immunosuppressed individuals discuss their risks with their health care provider.

This drinking water system is tested and Certified by NSF International to ANSI/NSF Standard 58 for cyst reduction. It meets the ANSI/NSF standard of reducing at least 99.95%* of cysts (including *Cryptosporidium*), however, because this is not 100%, immunosuppressed individuals should take the extra precaution of boiling their drinking water. According to the CDC-EPA, bringing water to a rolling boil for one minute is the most certain approach for killing *Cryptosporidium*.

All individuals should take adequate precaution when changing the filter cartridges, including wearing protective gloves, to avoid direct contact with the exhausted cartridges.

*For complete specifications, refer to the Performance Data Sheet.

SECTION I. INTRODUCTION

Your new Reverse Osmosis (R.O.) Drinking Water System uses a combination of filtration technologies to reduce unwanted contaminants in a water supply. The following steps combine to give you the best inclear sparkling drinking water:

MECHANICAL FILTRATION/ACTIVATED

CARBON—The Sediment/Carbon Prefilter will remove the larger particles such as silt, rust and scale. Its 5 micron (equal to 0.0002 inch) nominal rating helps to give maximum life to the R.O. Membrane. The activated carbon in the Prefilter will remove any chlorine that may be present in the feed water. This pretreatment is also necessary for membrane protection.

REVERSE OSMOSIS MEMBRANE—The R.O. Membrane is the heart of the filtration system. It is designed to reduce the dissolved mineral content of the water. Minerals picked up in the environment by the water are measured as Total Dissolved Solids (TDS). In the Reverse Osmosis process, dissolved minerals are separated from the incoming water (Feed Water) to produce the product water (the Permeate). The excess minerals are rinsed to drain (the Reject Water).

The membrane is a specially constructed, fully aromatic polyamide film, and is classified as a Thin Film Composite (T.F.C.).

The spiral wound construction of the R.O. Membrane provides maximum surface area for water production and is less susceptible to fouling by particulate matter, turbidity and colloidal materials.

ACTIVATED CARBON—The Activated Carbon Post Filter contains carbon particles with a vast network of pores. The tremendous surface area of these pores (typically 800–1200 square

meters per gram of carbon) gives the carbon very good adsorptive sites for substances that contribute to tastes and odors.

IN-LINE ACTIVATED CARBON POST

FILTER—The In-Line Activated Carbon Post Filter is located after the Holding Tank and reduces the tastes and odors that may pass through the system. It adds a final polish to the water.

AUTOMATIC SHUTOFF VALVE—The ASO Valve senses when the product water tank is full and closes the feed water supply to prevent excess reject water from going to drain when the unit is not producing water.

WATER QUALITY MONITOR—The Water Quality Monitor has been integrated into the faucet bezel for instant monitoring at the touch of a button. The monitor compares the level of the Total Dissolved Solids in the incoming (feed) water versus the product water and calculates the percent rejection. The monitor is preset to indicate a level of 75% rejection.

A green light indicates that the percent rejection is at or above the set (desired) value and that the system is producing quality water.

An amber light indicates that the product water quality is less than acceptable. Because the Water Quality Monitor was designed to operate best while the system is making water, a false reading may occur if tested when your R.O. drinking water system is not making water. Please empty the storage tank, wait 15 minutes for the system to begin making water, and test your water quality again. If the Water Quality Monitor light is still amber, please contact a water treatment professional for service. The Water Quality Monitor requires a 9 volt battery, which is included.

IMPORTANT NOTICES:

This reverse osmosis system contains replaceable treatment components critical for effective performance. It is the user's responsibility to, and the manufacturer strongly recommends that the user, periodically test the product water to verify the system is performing satisfactorily.

This system is acceptable for treatment of influent concentrations of no more than 27 mg/l nitrate and 3 mg/l nitrite in combination measured as N and is certified for nitrate/nitrite reduction only for water supplies with a pressure of 40 psig (280 kPa) or greater.

DO NOT USE WITH WATER THAT IS MICROBIOLOGICALLY UNSAFE OR OF UNKNOWN QUALITY, WITHOUT ADEQUATE DISINFECTION BEFORE OR AFTER THE SYSTEM. Systems certified for cyst reduction may be used on disinfected water that may contain filterable cysts.

SECTION II. SPECIFICATIONS

TABLE A – QUALIFIED SYSTEM PERFORMANCE

Because the performance of an R.O. Membrane is highly dependent upon pressure, temperature and TDS, the following should be used for comparison purposes only.

	U.S.	Metric
Membrane Production ¹	35 ± 5 gpd	(114–151 lpd)
Membrane TDS Reduction ¹	95% minimum	95% minimum
System Production ²	10 gpd	38 lpd
TDS Reduction ²	90%+ typical	90%+ typical
Drain (reject water) Flow	3–5 x product flow	3–5 x product flow
Empty Storage Tank Precharge	5–7 psig air	35–48 kPa air
Storage Tank Capacity ³	RO Mate 4E = 2.1 gallons	RO Mate 4E = 7.9 liters

¹ Industry standards measure RO Membranes performance with no backpressure on the product water, at 65 psig (450kPa) and 77°F (25°C). Further conditions on the above are 500 ppm TDS and a 15% recovery rate. Production rate and TDS reduction figures are for a new Membrane that has been rinsed for 24 hours. The production rate of a new Membrane can decrease by 10% per year or more, depending upon the scaling and fouling tendencies of the Feed Water.

² Actual capacity measured at 50 psig, 77°± 2°F, and 735 mg/l TDS per ANSI/NSF Standard 58.

³ 5 psig precharge and 40 psig water pressure in tank.

TABLE B – RECOMMENDED OPERATING LIMITS FOR FEED WATER

Specifications	T.F.C. Membrane
Water Pressure	40–100 psig (280–690 kPa)
TDS	2000 ppm (also mg/l) max.
Temperature	40–100°F (4–38°C)
pH	3–11
Hardness	Less than 10 gpg (170 mg/l) or soften
Iron	Less than 0.1 ppm (also mg/l)
Manganese	Less than 0.05 ppm (also mg/l)
Hydrogen Sulfide	None
Chlorine	None (See note)
Bacteria	Must be potable**

NOTE: Chlorine will damage a T.F.C. Membrane. The Sediment/Carbon Prefilter will remove chlorine from the incoming water. Change filter every 6 months, more often if the water contains more than 1 ppm chlorine.

****DO NOT USE WITH WATER THAT IS MICROBIOLOGICALLY UNSAFE OR OF UNKNOWN QUALITY, WITHOUT ADEQUATE DISINFECTION BEFORE OR AFTER THE SYSTEM.**

SECTION III. PREPARATION

A. Major System Components

The following components comprise the R.O. Drinking Water System. (Refer to Fig. 1, below for general system layout.)

1. An R.O. Manifold assembly.
2. Housings and Housing O-rings.
3. A Drinking Water Holding Tank.
4. A Dispensing Faucet with Water Quality Monitor Assembly.
5. A Feed Water Saddle Valve.
6. A Drain Clamp.
7. Plastic Tubing and tube connectors.
8. A Reverse Osmosis Membrane sealed in a plastic bag.
9. A Sediment/Carbon Prefilter, shrink wrapped.
10. An Activated Carbon Post Filter, shrink wrapped.
11. An In-Line Activated Carbon Post Filter, shrink wrapped.
12. Nitrate/Nitrite Test Kit.
13. Other items necessary for installation may include wood screws or machine screws and nuts for mounting the manifold, or concrete anchors for hanging on basement wall. Additional tubing or tube connectors. Plastic wire ties for organizing tubing.

TYPICAL PURO-35T UNDER SINK INSTALLATION DIAGRAM

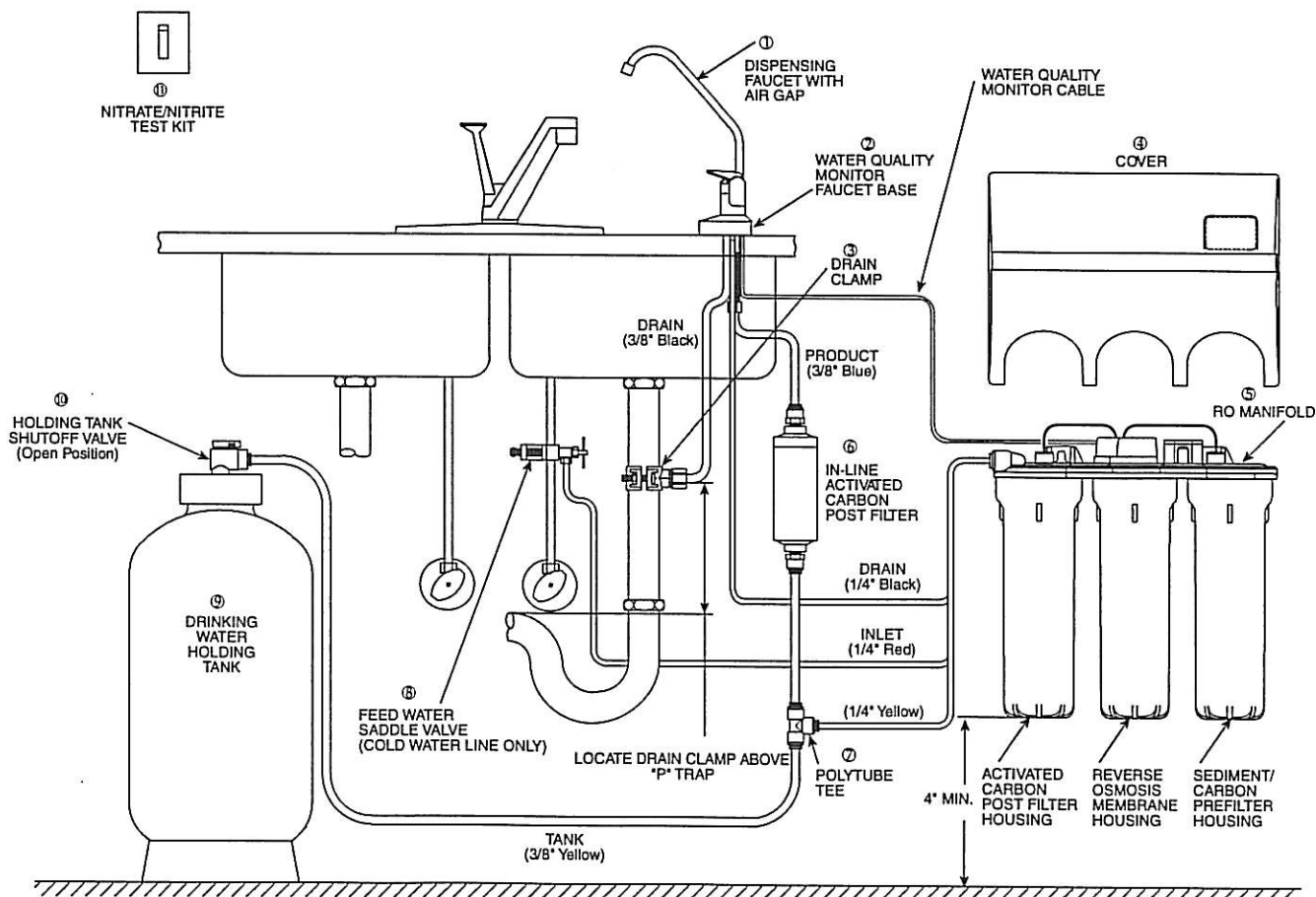
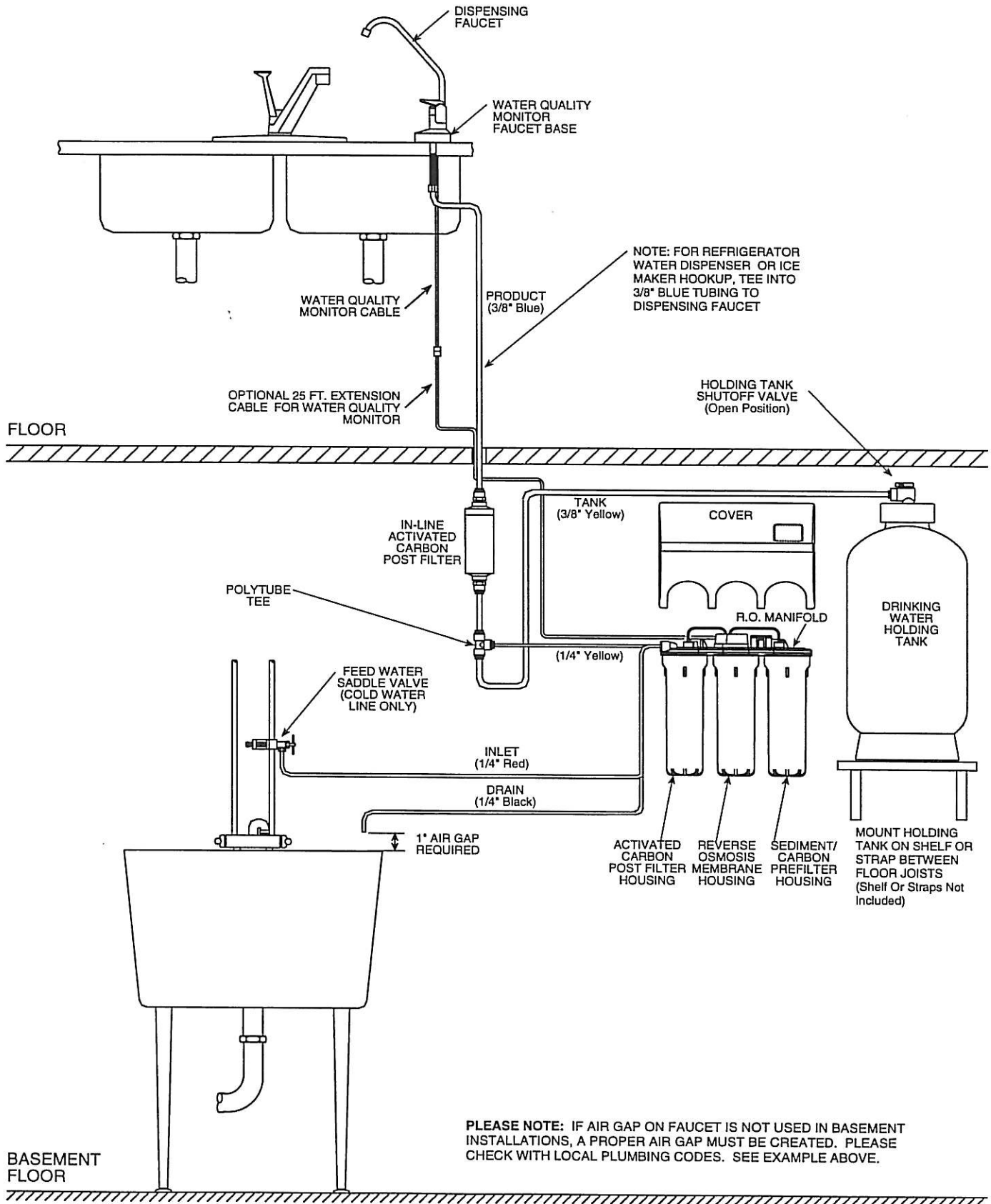

Figure 1

OPTIONAL PURO-35T BASEMENT INSTALLATION DIAGRAM



B. Tools Recommended for Installation

The following tools will cover most of the installation sites encountered:

1. $\frac{3}{8}$ " variable speed electric drill.
2. Extension work light with outlet.
3. Safety glasses.
4. $1\frac{1}{4}$ " porcelain hole cutter kit.
5. $1\frac{1}{4}$ " Greenlee hole punch and $\frac{1}{8}$ " and $\frac{1}{2}$ " metal drill bits for pilot hole.
6. Center punch and hammer.
7. $1\frac{1}{4}$ " wood bit.
8. Concrete drill bits.
9. Assorted wood and metal drill bits including $\frac{7}{32}$ " metal drill bit.
10. Phillips head and flat blade screwdrivers.
11. $\frac{1}{2}$ ", $\frac{9}{16}$ " and $\frac{5}{8}$ " open end wrenches.
12. 10" Crescent wrench with jaws taped to hold faucet.
13. Basin wrench or 10" pipe wrench.
14. Teflon tape.
15. Wide masking tape or duct tape.
16. Plastic tubing cutter.
17. Extra plastic tubing.
18. Low range air pressure gauge.
19. Bicycle hand air pump.
20. Small bottle of liquid chlorine bleach.
21. Graduated measuring cylinder.
22. Paper towels, wisk broom and assorted clean up materials.

C. Site Selection for Major System Components

The R.O. System was designed to fit under a sink, however, because of space limitations or other reasons, the system's flexible design allows for other locations. When determining the location remember that access to a cold water tap line, the household drain, and ease of filter replacement are important considerations.

All components and tubing should be located in an area not exposed to freezing temperatures. If winter temperatures are severe, the area should be above the minimum temperature listed in Table B, page 2 for proper performance. Do not expose unit or tubing to direct sunlight.

1. **Dispensing Faucet**—The faucet should be placed near the sink where drinking water is normally obtained. Convenience of use (filling of water pitchers and glasses), and an open area beneath the faucet under the sink for attaching product and drain tubing are considerations. A 2" diameter flat surface is required above and below the installation site. The thickness of the mounting surface should not exceed $1\frac{1}{4}$ ". Watch for strengthening webbing on the underside of cast iron sinks.
2. **Drinking Water Holding Tank**—The Holding Tank may be placed where it is convenient within 10 feet of the faucet; under the sink or in an adjacent cabinet are best the choices. If a longer run of tubing is required, the tubing should be the $\frac{3}{8}$ " diameter OD size to prevent a high pressure drop. Remember, these tanks can weigh up to 30 pounds when full of water; a firm, level area is required.
3. **R.O. Manifold Assembly**—The manifold can be installed on either the right or left side of the under-sink area or a cabinet. The right side is recommended because all the tubing will be to the back of the cabinet and out of the way. Installation in the basement is also an option; one location is near the laundry/utility sink where cold potable water and drain access are handy. The mounting location should allow adequate clearance and accessibility for cartridge changes.

4. **Feed Water Connection**—The Feed Water Saddle Valve should be located as close to the manifold assembly as possible. USE A POTABLE COLD WATER SUPPLY ONLY. Softened water is preferred as it will extend the life of the R.O. Membrane.

5. **Drain Connection**—The waste water must go to drain through an anti-siphon air gap. The air gap is provided for in the base of the faucet. If discharging into a utility sink or standpipe, an air gap of greater than 1" above the flood rim must be provided.

Do NOT connect the system drain line to the dishwasher drain or near the garbage disposal. Backpressure from these units may cause the air gap to overflow.

SECTION IV. INSTALLATION STEPS

All plumbing should be done in accordance with state and local plumbing codes.

NOTE: Some codes may require installation by a licensed plumber; check with the local plumbing authority prior to installation.

In restricted under-sink areas, it may be easier to install the faucet first. Allow adequate tubing lengths for any final component position.

A. Faucet With Water Quality Monitor Installation

The faucet contains an anti-siphon air gap. While the system is producing water, the drain water flows from the R.O., through the air gap and then to the household drain. The purpose of the air gap is to prevent water in the drain from backing up into the R.O. Drinking Water System.

NOTE: For proper installation the Air Gap Faucet has a critical level line "CL" marked on its body and should be mounted so that the "CL" line is at least one (1) inch (26mm) above the flood level rim of the sink.

The easiest installation is to use an existing spray attachment hole. If the spray faucet hole is not available, then the sink top must be drilled. Choose a convenient location as described in Sec. III, C.1, page 5.

1. Mark the location of the center of the faucet base.

2a. Drilling a stainless steel sink:

- Center punch the hole to provide a starting point for the drill.
- Start with a smaller drill as a pilot, and then drill a ½" diameter hole to accept the bolt of a 1¼" Greenlee Hole Punch (1¼" chassis punch).
- Clean away any chips.
- Install the punch and tighten the nut to cut the hole.
- Deburr any sharp edges.

2b. Drilling a porcelain sink:

It is best to use a special 1¼" diameter cutter designed for porcelain. A carbide tipped masonry bit is a second choice.

- Place a piece of tape over the area to be drilled to help prevent chipping.
- Drill a pilot hole for the porcelain cutter. Use the pilot drill supplied with the kit or a carbide tipped drill.
- When drilling the 1¼" hole, drill slowly and carefully; the porcelain chips easily.
- After drilling, clean the area well. Iron filings, if left in place, can cause rust stains.

2c. Drilling a counter top:

NOTE: The counter top must be less than 1¼" thick. (See Sec. IV, A.2b, page 6.) Treat ceramic tile as porcelain until the tile is penetrated, then use the carbide tipped metal cutter.

Formica counter tops may be drilled with a good 1¼" wood bit, drilling a 3/32" pilot hole will help keep the bit going straight.

3. Assemble and attach the Faucet, Water Quality Monitor Faucet Base and tubing (refer to Fig. 2A & 2B, page 7.)

- Assemble the Body and Spout by removing the plastic shipping plug from the Body and then firmly pressing in the Spout.
- Locate the ¼" Black Drain Tubing which is shipped loose in the box. Connect the Black Drain Tubing to the ¼" Hose Barb on the Dispensing Faucet by firmly pressing over the barb. Allow the tubing to relax,

LONG REACH AIR GAP FAUCET WITH WATER QUALITY MONITOR

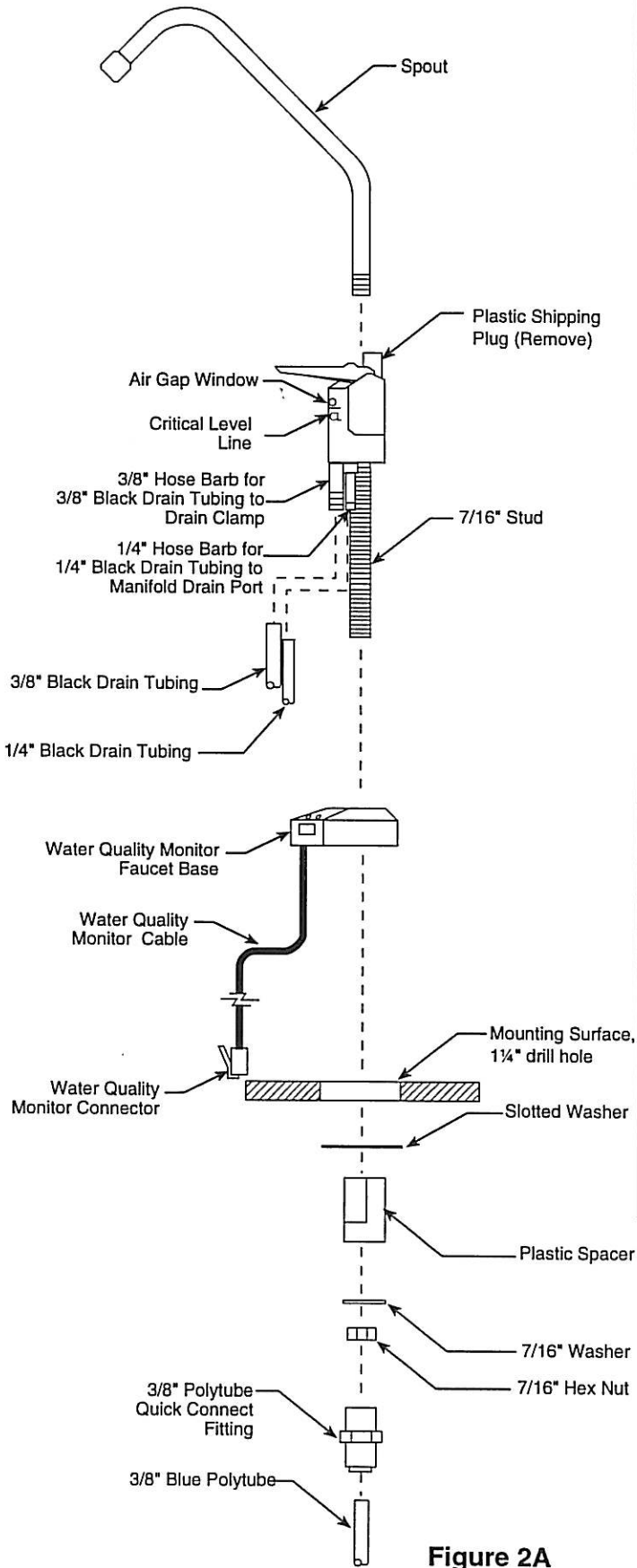

Figure 2A

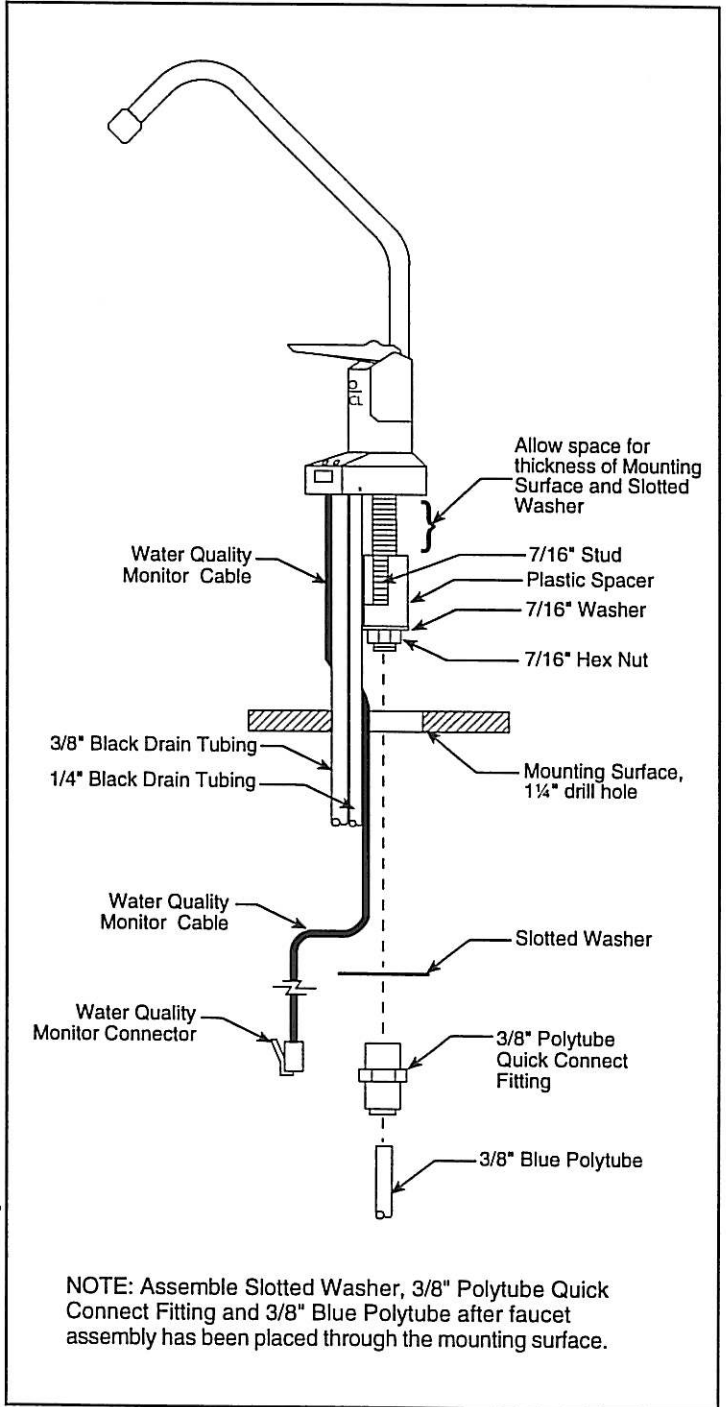

Figure 2B

then press firmly again to insure proper seating. The end of the Black Drain Tubing that should be inserted into the "Drain" port on the R.O. Manifold will have a blue drain restrictor in it. DO NOT attach this end to the Dispensing Faucet.

- Locate the $\frac{3}{8}$ " Black Drain Tubing which is shipped loose in the box. Firmly press one end of the tubing over the $\frac{3}{8}$ " drain outlet hose barb on the Dispensing Faucet. Allow tubing to relax, then press firmly again to insure proper seating. No connectors are required when attaching tubing to Hose Barbs.
- Slide Water Quality Monitor Faucet Base over $\frac{1}{4}$ " Black Drain Tubing, $\frac{3}{8}$ " Black Drain Tubing and $\frac{7}{16}$ " stud screw and seat with Amber/Green LED's aligned under Air Gap Window on Dispensing Faucet. (See Figure 2A, page 7.)
- Assemble the Plastic Spacer (with open end upwards and facing tubing), the $\frac{7}{16}$ " Washer and the $\frac{7}{16}$ " Hex Nut onto the $\frac{7}{16}$ " stud screw. Do Not tighten at this point.
- From the top of the counter place the stud, tubing and Water Quality Monitor Connector Cable through the mounting hole. See Figure 2B, page 7.
- From the bottom of the counter top slide the Slotted Washer between the counter top and the Plastic Spacer with the open end towards the tubing.
- Tighten the $\frac{7}{16}$ " Hex Nut to hold everything in place.
- Rotate the Spout and Body into position making sure the faucet body is square and properly aligned with the Water Quality Monitor Faucet Base. Align the Slotted Washer and the Spacer to allow access to the Hose Barbs, and tighten the Hex Nut while holding the faucet in alignment with a padded crescent wrench. Do not over tighten.

- To the end of the $\frac{7}{16}$ " stud, screw on the $\frac{3}{8}$ " Polytube Quick Connect Fitting. Once snug by hand take a pair of pliers and tighten the fitting an additional half turn. Don't over tighten.

- Locate the $\frac{3}{8}$ " Blue Product Water Tubing. Firmly press one end into the $\frac{3}{8}$ " Polytube Quick Connect Fitting.

Note: If you want to pull the tubing out for some reason, push the ring around the tubing in and pull the tubing out.

B. Feed Water Saddle Valve Installation

Decide on location. Do NOT connect to a hot water feed line. If you are not sure of the supply, run the hot water and feel the supply piping. Water over 100°F may cause permanent damage to the R.O. Membrane. (Refer to Fig. 3 page 9.)

1. Shut off the water supply and drain the line.
- 2a. To install on (soft) Copper Tubing supply line:
 - Turn the Handle of the Feed Water Saddle Valve counter clockwise (outward) until the lance does not protrude from the gasket. It may have to be pushed in.
 - Assemble the Feed Water Saddle Valve on the tubing.
 - for $\frac{3}{8}$ " OD tubing use the back plate side with the small groove to prevent distortion of the tubing.
 - for larger tubing (up to $\frac{5}{8}$ " OD) use the large groove of the back plate.
 - Assemble and tighten the brass screw.
 - To pierce the tubing, turn the Valve Handle fully clockwise (inward). A small amount of water may escape from the outlet until it is fully pierced.
 - When you feel the Valve Handle firmly seated in the clockwise direction, the copper tube is pierced and the valve is closed.

- 2b. To install on (hard) Steel or Brass Tubing supply line.
- The supply line should now be drained. Use a battery powered or properly grounded drill to avoid shock hazard.
 - Drill a $\frac{3}{16}$ " hole in the supply line; (do not drill through the opposite wall).
 - Turn the handle to expose the lance no more than $\frac{3}{16}$ " beyond the rubber gasket.
 - Place the body of the valve over the hole so that the lance fits into the hole.
 - Assemble and tighten the brass screw.
 - Turn the Valve Handle clockwise (inward) until firmly seated. The valve is closed.
3. With the Feed Water Saddle Valve closed, open the sink faucet and the water supply and allow the water to run for a few minutes to flush any debris caused by the installation.
- Close the faucet and check the Feed Water Saddle Valve for leaks.

FEED WATER SADDLE VALVE

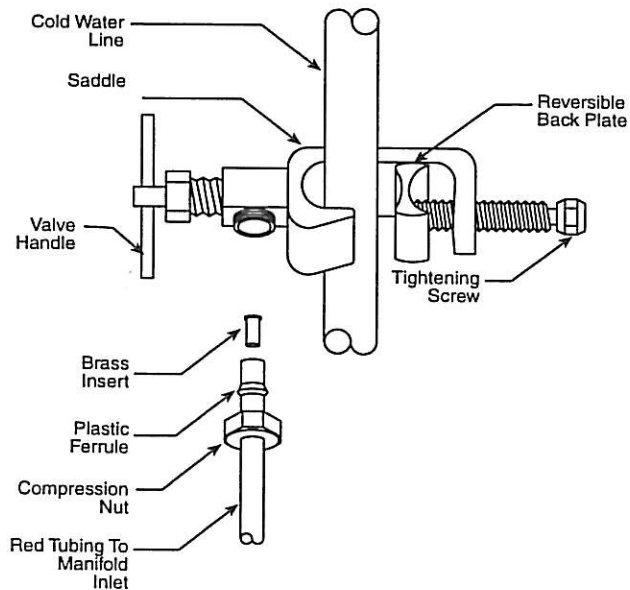

Figure 3

C. Drain Clamp Installation

Choose the drain outlet location per Sec. III, C.5, page 6.

The following are instructions for discharging into the sink drain pipe. (Refer to Fig. 1, page 3.)

1. Position the Drain Clamp on the sink drain pipe above the drain trap. Allow room for drilling. Tighten securely.
2. Use a battery powered or properly grounded drill. Using the Clamp port as a drill guide, drill a $\frac{7}{32}$ " hole through the wall of the drain pipe. Do NOT penetrate the opposite side of the pipe.
3. Locate the $\frac{3}{8}$ " Black Drain Tubing connected to the Dispensing Faucet. Route to the tubing to the Drain Clamp and trim to length.

NOTE: When cutting the polytubing make clean, square cuts, failing to do so could result in poor connections and possible leaks.

CAUTION: The lowest point of the line should be the point of connection to the Drain Clamp. There should be no sag in the line as this may cause excessive noise as the reject water is flowing to drain.

- Refer to Fig. 4, page 10. To connect the Drain Tubing, install the Compression Nut and the Brass Insert.

- Insert the tubing into the Drain Clamp and tighten the Compression Nut.

3/8" DRAIN CLAMP ASSEMBLY

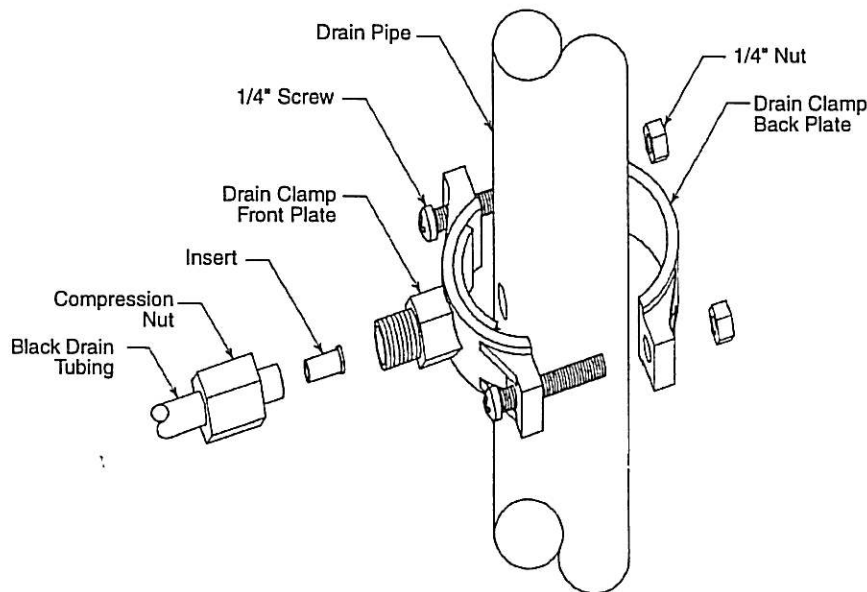

Figure 4

D. R.O. Manifold Assembly Installation

Locate the site per Sec. III, C.3, page 5. Various installation sites will require different types of mounting fasteners; be sure the fastener selected will provide a firm, solid mounting. A support panel may be necessary on thin cabinet walls or to span between wall studs on particleboard or drywall.

Do not drill through exterior cabinet walls or leave sharp wood screw points exposed in readily accessible cabinet interiors.

The close proximity of a dishwasher or a trash compactor may require special fabrication of a mounting plate.

1. The mounting bracket will accept either #10 or #12 (5mm) mounting screws spaced on 6" (15 cm) centers. Allow at least 4" (10 cm) of clearance beneath the filter housings to accommodate filter changes. Mark the two locations (the bracket can be used as a template). Install the screws and tighten them until the heads are about $\frac{5}{8}$ " from the wall.
2. Locate the $\frac{1}{4}$ " Red Feed Water Tubing. Remove the red plug from the fitting labelled "In" on the manifold and insert the tubing. Reference the special supplement sheet in the carton for proper connection of all tubing

and removal of plugs. Run the tubing along its course to the Feed Water Saddle Valve, trim to length. (Refer to Fig. 1, page 3.)

Refer to Fig. 3, page 9. To the end of the red polytube install the Compression Nut, the Plastic Ferrule, and the Brass Insert. Connect to the Feed Water Saddle Valve.

3. Locate the $\frac{1}{4}$ " Black Drain Tubing connected to the Dispensing Faucet. Remove the black plug from the fitting labelled "Drain" on the manifold and insert the tubing. The end of the Black Drain Tubing that should be inserted into the "Drain" port will have a blue drain restrictor in it. If tubing needs to be trimmed to length, carefully slit $\frac{1}{4}$ " Black Drain Tubing end that has the blue drain restrictor in it being careful not to damage the hose barb on the drain restrictor. Remove restrictor from tubing, make a square cut, and reinsert the drain restrictor. Allow the tubing to relax, then press drain restrictor firmly again to insure proper seating.
4. Locate the $\frac{1}{4}$ " yellow tubing with the tee attached to one end. Remove the yellow plug from the fitting labelled "Out" on the manifold and insert the tubing.

5. Locate the $\frac{3}{8}$ " Blue Product Water Tubing attached to the Dispensing Faucet. Firmly press one end into the tee. (Refer to Fig. 1, page 3.) The fittings will grab the tubing and seal it in place. Make sure the tubing is pressed all the way in to create a pressure tight connection.

NOTE: If you want to pull the tubing out for some reason, push the ring around the tubing in and pull the tubing out.

6. Hang the Manifold Assembly on the mounting screws and tighten. **DO NOT OVERTIGHTEN.**
7. Remove the wrapping from the In-Line Activated Carbon Post Filter. Slice the $\frac{3}{8}$ " Blue Polytube where it would be convenient to install and change the In-Line Filter. Make a clean straight cut to insure proper connections. The "Out" port on the In-Line Filter should be towards the faucet. Firmly press in the tubing. The fittings will grab the tubing and hold and seal it in place. Make sure the tubing is pressed all the way in to create a pressure tight connection.

E. Position the Drinking Water Holding Tank and Make the Final Hose Connections.

1. Check the tank precharge pressure. Make sure it is between 5 to 7 psig. If not, use a bicycle hand pump or other pump to bring the pressure up to the 5 to 7 psig range.
2. Pull the cap/plug off the top of the tank where the Tank Shut-Off should go. (Refer to Fig. 1, page 3.)
3. Wrap the white Teflon tape, included in the box, three times around the $\frac{1}{4}$ " male outlet thread. Wrap in the direction of the threads (clockwise when looking down on the Holding Tank). The tape will act as a thread sealant. Screw on the Holding Tank Shut-Off Valve.
4. Locate the $\frac{3}{8}$ " Yellow Tubing. Firmly press one end into the Holding Tank Shut-Off Valve and the other end into the tee. (Refer to Fig. 1, page 3.) The fittings will grab the tubing and seal it in place. Make sure the tubing is pressed all the way in to create a pressure tight connection.

F. Start Up

At time of start up and each time the filters are changed the system should be sanitized (also see Operation and Maintenance Sec. V, B.1-4, page 13).

1. Sanitizing the system. Use a drip pan to aid clean-up.

NOTE: The system should be sanitized BEFORE installing the Sediment/Carbon Prefilter, the Activated Carbon Post Filter or the RO Membrane.

- Use a good quality unscented 5¼% liquid chlorine household bleach.

- Open the Dispensing Faucet by lifting the black handle and open the Holding Tank Shut-Off Valve (the handle should be parallel with the valve body).

- Remove the plug on the underside of the manifold labelled "SEDIMENT/CARBON". Pour one capful of bleach (this is approximately 2 tsp. or 10 ml) into one of the white Housings. Insert a Housing O-ring into the Housing groove, (press firmly in place). Engage and firmly tighten the Housing hand tight only.

- Remove the plugs labelled "MEMBRANE" and "ACTIVATED CARBON" from the underside of the manifold. To each of the remaining white Housings, add one capful of bleach. Insert a Housing O-ring, engage and firmly tighten the Housings hand tight only.

- Slowly open the Feed Water Saddle Valve (turning counter clockwise).

- As soon as the water begins to come out of the Dispensing Faucet, close the Faucet.

- Let stand for 15 minutes.

NOTE: During this time, check the system carefully for leaks.

- At the end of 15 minutes, CLOSE the Feed Water Saddle Valve and open the Dispensing Faucet.

- Allow the Holding Tank to completely drain, then remove the Sediment/Carbon Prefilter Housing (the farthest of the three from the In-Out ports), empty, and install the Sediment/Carbon Prefilter. Firmly tighten the Housing hand tight only.

- Remove the Activated Carbon Post Filter Housing (the closest of the three to the In–Out ports), empty, and install the Activated Carbon Post Filter. Firmly tighten the Housing hand tight only.
2. Installing the R.O. Membrane:
 - Remove the R.O. Membrane Housing, (the middle one), and empty.
 - Insert the Membrane up into the manifold. (The O–rings should be up toward the manifold.) Check the Housing O–ring for proper position in its groove, engage and firmly tighten the Housing hand tight only.
 3. Rinsing the system:
 - Slowly open the Feed Water Saddle Valve fully counter clockwise.
 - The Holding Tank Valve should be open.
 - Check the Air Gap Window on the Dispensing Faucet to be sure that the drain water is flowing. (Refer to Figure 2A, page 7.) The R.O. System is now making water.
 - Do not open the Faucet for at least 5 hours.
 - Do not use the first three full tanks of water.

CAUTION: The R.O. Membrane is shipped with a preservative in it (0.5% sodium metabisulfite). This will be rinsed out with the first water produced. Allow the Holding Tank to fill (overnight) and discard the first three full tanks of production. It takes approximately 5 hours to make a full tank.

When the Faucet is first opened, expect air and carbon fines (very fine black powder) from the In–Line and Activated Carbon Post Filters to be rinsed out. This is normal for the first tank of water or after the Activated Carbon Post Filters are changed.

SECTION V. OPERATION & MAINTENANCE

A. Normal Operation

1. It is normal for the Total Dissolved Solids (TDS) of the water to be higher than normal during the first 5 gallons of operation, this is due to the sanitizing solution and the new Post Filters. After this water is rinsed to drain, the removal rate should stabilize at a value of greater than 75%. The Water Quality Monitor was designed to measure water quality when the R.O. system is making water. In order to assure you are getting an accurate reading, empty the holding tank, wait 15 minutes until the system begins making water, and then test the TDS with the monitor.
2. R.O. systems produce drinking water at relatively slow rates, it can take up to 5 hours or more to fill the Holding Tank. Normal operation is to let the Holding Tank fill with water and then draw water as is needed. When the pressure in the Holding Tank falls to a given pressure (as the water is being used) the Automatic Shut–Off Valve (ASO Valve) will start water production and the system will refill the Holding Tank. When the Holding Tank is full and no water is being used, the ASO Valve will automatically shut off the feed water to conserve water. The more water that is used (up to the capacity of the system) the better the R.O. system will function. Other uses for the water are flowers, pets and rinsing glassware.

With each use it is recommended that you run the tap for at least 10 seconds prior to using water. This is especially important if the water tap has not been used daily. After periods of non–use, such as a week of vacation, it is better to empty the Holding Tank and allow the system to produce fresh water for use. If the system is not used for 3–4 weeks or longer, it is a good idea to resanitize the system and to change the prefilter and post filters.

B. Changing Filters

THIS R.O. SYSTEM CONTAINS FILTERS WHICH MUST BE REPLACED AT REGULAR INTERVALS TO MAINTAIN PROPER PERFORMANCE. USE ONLY FACTORY APPROVED FILTERS.

All individuals should take adequate precautions when changing the filters, including wearing protective gloves, to avoid direct contact with the exhausted filters.

The recommended interval for changing the filters (not the R.O. Membrane) is every six (6) months. Typical T.F.C. Membrane life expectancy is three years. Local conditions may dictate more frequent changes.

NOTE: If the R.O. Membrane is to be replaced, see Sec. IV, F.1–3, page 11, for the proper procedure.

Use a drip pan to catch any water that may spill when the Filter Housings are removed. Refer to Fig. 1, page 3 for component location.

1. Close the Feed Water Saddle Valve by turning fully clockwise and open the Dispensing Faucet by lifting the handle. Allow the Holding Tank to empty.
2. Loosen and remove the Sediment/Carbon Prefilter and the Activated Carbon Post Filter Housings. Discard the filters.
3. Wash the inside of the Housings using a mild detergent and a soft cloth. Do not use abrasive cleaners or pads. Thoroughly rinse all soap from the Housings before reassembly.
4. To sanitize the system and replace the filters:

NOTE: The system should be sanitized before installing the Sediment/Carbon Prefilter and Activated Carbon Post Filter.

- Use a good quality unscented 5¼% liquid chlorine household bleach.
- Add one capful of bleach (this is 2 tsp. or 10 ml) to the Sediment/Carbon Prefilter Housing and temporarily install the Housing without the Sediment/Carbon Prefilter. Check the Housing O–ring for proper position in its groove, engage and firmly tighten the Housing hand tight only.

- Add one capful of bleach to the Activated Carbon Post Filter Housing. Carefully fill the Housing with tap water and temporarily install the Housing without the Activated Carbon Post Filter.
 - The Dispensing Faucet should be open, slowly open the Feed Water Saddle Valve.
 - As soon as water begins to drip out of the Dispensing Faucet, close the Faucet.
 - Let the system stand for 15 minutes.
 - At the end of 15 minutes, in the following order, close the Feed Water Saddle Valve, close the Holding Tank Valve and open the Dispensing Faucet to release the pressure.
 - Remove the Sediment/Carbon Prefilter Housing and empty. Remove the wrapping and install the Sediment/Carbon Prefilter. Firmly tighten the Housing hand tight only.
 - Remove the Activated Carbon Post Filter Housing and empty. Remove the wrapping and install the Activated Carbon Post Filter. Firmly tighten the Housing hand tight only.
 - Disconnect the yellow product water tubing that runs from the Holding Tank to the Tee (see Fig. 1, page 3). Put 50 drops of bleach (this is ½ tsp. or 3 ml) into the tubing and reconnect it to the Tee.
- NOTE:** Now is the convenient time to change the In–Line Activated Carbon Post Filter, see Sec. V, C.1–6, page 14.
- Slowly open the Feed Water Saddle Valve. When water begins dripping out of the Dispensing Faucet, in the following order, close the Faucet and then open the Holding Tank Valve.
 - Do not open the Faucet for at least 5 hours.
 - Discard the first three full tanks of water produced, they will contain chlorine.

C. Changing the In-Line Activated Carbon Post Filter

1. Close the Feed Water Saddle Valve by turning fully clockwise.
2. Close the Holding Tank Valve and then open the Dispensing Faucet to release the pressure.
3. Remove the In-Line Activated Carbon Post Filter. Disconnect the used Post Filter by pressing in the connector's collar and at the same time pulling the tube out of the fitting. Unscrew the fittings on the In-Line, re-Teflon tape them and install them on the new Post Filter. Do not over tighten the fittings.
4. Firmly reconnect the polytubes to the new Post Filter. (Refer to Fig. 5 below.)
5. Slowly open the Feed Water Saddle Valve.
6. When water begins dripping out of the Faucet, in the following order, close the Faucet and open the Holding Tank Valve. When the Faucet is first opened, expect air and carbon fines (very fine black powder), from the new Post Filter to be rinsed out. This is normal for the first tank of water.

IN-LINE ACTIVATED CARBON POST FILTER ASSEMBLY

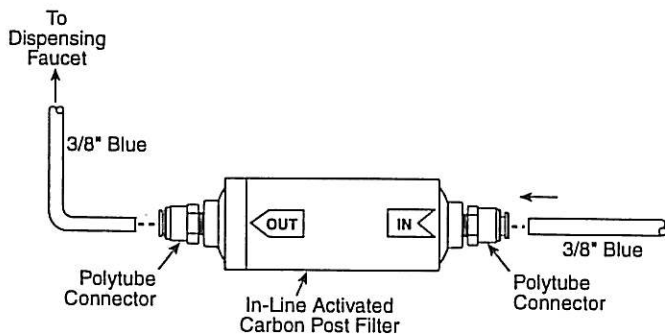

Figure 5

SECTION VI. TECHNICAL DATA

A. Water Quality

Water quality is normally measured with a special meter that measures the water's ability to conduct electricity. The more dissolved solids in the water, the higher the conductivity. The results are usually reported in **Parts per Million (ppm)** or **Milligrams per Liter (mg/l)** of **Total Dissolved Solids (TDS)**. (Although technically they are not exactly equal, in most discussions ppm = mg/l.)

R.O. Membranes are rated by the amount of dissolved solids that are rejected. This rating is a ratio of the TDS in the feed water to the TDS in the product water and is reported as **Percent Rejection**. If the feed water contained 100 ppm of TDS and the product water contained 10 ppm of TDS, 90 ppm have been rejected and the reject ratio is 90%.

$$\text{Percent Rejection} = \frac{\text{Feed TDS} - \text{Product TDS}}{\text{Feed TDS}} \times 100\%$$

EXAMPLE: Feed water is 500 ppm TDS and the product water is 75 ppm TDS.

$$\text{Percent Rejection} = \frac{500 - 75}{500} \times 100\%$$

$$\text{Percent Rejection} = 0.85 \times 100\% \text{ or } 85\%$$

B. Water Quantity

Water quantity is termed **Flux** or **Product Water Rate** and is measured as the amount of water produced in one day. It is reported as **Gallons per Day (gpd)** or **Liters per Day (lpd)**.

The flow of water to drain is the **Reject Water Rate** and is measured as **Gallons per Day (gpd)** or as **Milliliters per Minute (ml/min)**.

$$\text{Milliliters per minute} \times 0.38 = \text{gallons per day}$$

EXAMPLE: The drain flow will fill a graduated cylinder to the 150 ml mark in one minute.

$$150 \text{ ml/min.} \times 0.38 = 57 \text{ gpd}$$

If the container available measures ounces, use the following conversion:

$$\text{Ounces per minute} \times 11.2 = \text{gallons per day}$$

EXAMPLE: The product flow will fill 2½ ounces in two minutes.

$$2.5 \text{ oz.} \div 2 \text{ min.} = 1.25 \text{ oz./min.}$$

$$1.25 \text{ oz./min.} \times 11.2 = 14 \text{ gpd}$$

The **Reject Ratio** is the amount of water produced compared to the amount of water flowing to drain.

$$\text{Reject Ratio} = \frac{\text{Reject Rate}}{\text{Product Rate}}$$

EXAMPLE: The product rate is 14 gpd and the reject rate is 56 gpd.

$$\text{Reject Ratio} = 56 \div 14$$

$$\text{Reject Ratio} = 4 \text{ or } 4\text{-to-}1$$

The **Percent Recovery** is another way to measure the amount of water produced as compared to the amount actually used.

$$\% \text{ Recovery} = \frac{\text{Product Rate}}{\text{Feed Rate}} \times 100\%$$

NOTE: The total flow or feed water rate into the system is the sum of the product flow and the drain flow.

EXAMPLE: The product water rate is 14 gpd and the drain water rate is 56 gpd

$$\text{Feed Rate} = 14 \text{ gpd} + 56 \text{ gpd} = 70 \text{ gpd}$$

$$\% \text{ Recovery} = \frac{14 \text{ gpd}}{70 \text{ gpd}} \times 100\%$$

$$\% \text{ Recovery} = 0.20 \times 100\% \text{ or } 20\%$$

C. Net Pressure Differential

Most R.O. Membranes are rated at a standardized condition of 77°F (25°C) and 65 psig (450kPa) discharging to atmospheric pressure.

Product water quality and quantity greatly depend upon the **Net Pressure Differential** (Δp) across the R.O. Membrane. This pressure differential is a summation of the feed water pressure at the Membrane, which tries to push the water through, the pressure in the Holding Tank, which tries to push the water backwards and the osmotic pressure, which also tries to push the water backwards.

The **Osmotic Pressure** is in proportion to the dissolved minerals in the water and can be approximated by 1 psig for each 100 ppm of TDS

EXAMPLE: A feed water with 1500 ppm of TDS would exert a backward pressure of about 15 psig on the membrane.

$$\text{Net Pressure Differential} = \text{Feed Water Pressure} - \text{Holding Tank Pressure} - \text{Osmotic Pressure}$$

The higher the net pressure differential, the higher the quantity and quality of water produced.

Some loss of production is normal when using a pressurized Holding Tank.

D. WATER PRODUCTION RATE CHART

Feed Water		Estimated Water Production Rate in Gallons Per Day (gpd) and Liters Per Day (lpd) for Line Pressure of:													
Temp °F °C	TDS* mg/l	40 psig (280 kPa)		50 psig (345 kPa)		60 psig (414 kPa)		70 psig (483 kPa)		80 psig (552 kPa)		90 psig (621 kPa)		100 psig (690 kPa)	
		gpd	lpd	gpd	lpd	gpd	lpd	gpd	lpd	gpd	lpd	gpd	lpd	gpd	lpd
40 4	50	6.5	24.6	8.5	32.2	10.5	39.7	12.5	47.3	14.5	54.9	16.5	62.5	18.5	70.0
	500	5.6	21.2	7.6	28.8	9.6	36.3	11.6	43.9	13.6	51.5	15.6	59.0	17.6	66.6
	1000	4.6	17.4	6.6	25.0	8.6	32.6	10.6	40.1	12.6	47.7	14.6	55.3	16.6	62.8
	1500	3.6	13.6	5.6	21.2	7.6	28.8	9.6	36.3	11.6	43.9	13.6	51.5	15.6	59.0
50 10	50	9.9	37.5	12.9	48.8	15.9	60.2	19.0	71.9	22.0	83.3	25.0	94.6	28.1	106.4
	500	8.5	32.2	11.5	43.5	14.6	55.3	17.6	66.6	20.6	78.0	23.7	89.7	26.7	101.1
	1000	7.0	26.5	10.0	37.9	13.0	49.2	16.1	60.9	19.1	72.3	22.1	83.6	25.2	95.4
	1500	5.5	20.8	8.5	32.2	11.5	43.5	14.6	55.3	17.6	66.6	20.6	78.0	23.7	89.7
60 16	50	13.2	50.0	17.3	65.5	21.4	81.0	25.4	96.1	29.5	111.7	33.6	127.2	37.7	142.7
	500	11.4	43.1	15.5	58.7	19.5	73.8	23.6	89.3	27.7	104.8	31.7	120.0	35.8	135.5
	1000	9.4	35.6	13.4	50.7	17.5	66.2	21.6	81.8	25.6	96.9	29.7	112.4	33.8	127.9
	1500	7.3	27.6	11.4	43.1	15.5	58.7	19.5	73.8	23.6	89.3	27.7	104.8	31.7	120.0
70 21	50	16.6	62.8	21.7	82.1	26.8	101.4	31.9	120.7	37.0	140.0	42.1	159.3	47.2	178.7
	500	14.3	54.1	19.4	73.4	24.5	92.7	29.6	112.0	34.7	131.3	39.8	150.6	44.9	169.9
	1000	11.7	44.3	16.9	64.0	22.0	83.3	27.1	102.6	32.2	121.9	37.3	141.2	42.4	160.5
	1500	9.2	34.8	14.3	54.1	19.4	73.4	24.5	92.7	29.6	112.0	34.7	131.3	39.8	150.6
80 27	50	20.0	75.7	26.1	98.8	32.3	122.3	38.4	145.3	44.5	168.4	50.7	191.9	56.8	215.0
	500	17.2	65.1	23.3	88.2	29.5	111.7	35.6	134.7	41.8	158.2	47.9	181.3	54.1	204.8
	1000	14.1	53.4	20.3	76.8	26.4	99.9	32.6	123.4	38.7	146.5	44.9	169.9	50.1	189.6
	1500	11.1	42.0	17.2	65.1	23.3	88.2	29.5	111.7	35.6	134.7	41.8	158.2	47.9	181.3
90 32	50	23.3	88.2	30.5	115.4	37.7	142.7	44.9	169.9	52.1	197.2	59.2	224.1	66.4	251.3
	500	20.1	76.1	27.3	103.3	34.5	130.6	41.7	157.8	48.8	184.7	56.0	212.0	63.2	239.2
	1000	16.5	62.5	23.7	89.7	30.9	117.0	38.1	144.2	45.2	171.1	52.4	198.3	59.6	225.6
	1500	12.9	48.8	20.1	76.1	27.3	103.3	34.5	130.6	41.7	157.8	48.8	184.7	56.0	212.0

*Total Dissolved Solids (TDS) measured in Parts Per Million (ppm)/Milligrams per Liter (mg/l).

Please Note: This chart is based upon a start-up of a system when the storage tank is empty, (7 psig/48 kPa precharge). As the tank fills, and backpressure from the tank increases, the gpd/lpd rating will decrease.

IMPORTANT! If the water production rate is within the highlighted area (marked with dotted lines), change the drain restrictor to a 125 gpd (473 lpd) drain restrictor, color-coded purple.

SECTION VII. TROUBLE SHOOTING GUIDE

Problem	Possible Cause	Solution
Low quantity of Product Water from Holding Tank	Feed Water Saddle Valve is plugged or closed.	Open Valve or unclog.
	Clogged Sediment/Carbon Prefilter or Activated Carbon Post Filter.	Replace filters.
	Low water pressure.	Feed Water pressure must be above 40 psig.
	R.O. Membrane is fouled.	See Feed Water operating limits. Correct cause of fouling, replace Membrane.
	Plugged In-Line Activated Carbon Post Filter.	Replace Post Filter.
	Air precharge pressure in Holding Tank is too high.	Empty water from Holding Tank, and with the faucet open, adjust air pressure to 5–7 psig (35–48 kPa) range.
	Air precharge is too low	
	Air bladder in the Holding Tank is ruptured.	Replace tank.
	Holding Tank Valve is closed.	Open Valve.
	No drain flow, the Drain Restrictor is plugged.	Clear or replace Drain Restrictor.
	No drain flow, the drain orifice in the Air Gap Faucet is plugged.	Clear or replace the Air Gap Faucet.
	The Check Valve is stuck.	Free check.
	The ASO Valve is malfunctioning.	Replace ASO Valve components.
Low pressure at the Dispensing Faucet	In-Line Activated Carbon Post Filter is plugged.	Replace Post Filter.
	Air precharge in the Holding Tank is too low.	Empty water from Holding Tank and with the faucet open, adjust the air pressure to 5–7 psig (35–48 kPa) range. Check for leakage at the Air Valve Stem.
	Holding Tank Valve is partially closed.	Open Valve.
	The dispensing Faucet is out of adjustment or faulty.	Repair or replace Dispensing Faucet.
	Heavy water use, Holding Tank is depleted.	Allow Holding Tank to refill (adding a second Holding Tank will increase storage capacity).
	Low Water Production.	See Low Quantity of Product Water from Holding Tank section above.
	High Total Dissolved Solids (TDS) in the Product Water	Clogged Sediment/Carbon Prefilter or Activated Carbon Post Filter.
Low Water Pressure.		Feed Water Pressure must be above 40 psig. Check Feed Water Saddle Valve.
R.O. Membrane O-ring is crimped.		Check O-ring.
R.O. Membrane brine seal is not sealing up into the manifold head.		Check the brine seal.
R.O. Membrane is expended.		If Membrane life is unusually short, find and correct the problem. Replace Membrane.

Problem	Possible Cause	Solution
High Total Dissolved Solids (TDS) in the Product Water (continued)	The Product Water and Drain Water lines are reversed.	Correct plumbing.
	No drain flow, Drain Restrictor is clogged.	Clear or replace Drain Restrictor.
	No drain flow, the drain orifice in the Air Gap Faucet is plugged.	Clear or replace Air Gap Faucet..
	The ASO Valve is not closing.	Repair or replace the ASO Valve Components.
	New In-Line or Activated Carbon Post Filter not rinsed completely.	Flush with several full tanks of Product Water.
	The Feed Water TDS has increased.	An increase in Feed Water TDS will give a corresponding increase in Product Water TDS.
Tastes and odors in the Product Water	The In-Line or Activated Carbon Post Filter is exhausted.	Replace Filters.
	There is foreign matter in the Holding Tank.	Clean, flush and sanitize the system. Replace the filters.
	The Product Water and Drain Water lines are reversed.	Correct plumbing.
	Dissolved gasses in the Feed Water.	Pretreat Feed Water to remove dissolved gasses.
	Increase in Product Water TDS.	See high TDS in the Product Water section.
Drain Water overflows at the Air Gap Faucet	Air Gap is blocked.	Clear Air Gap. Rinse with vinegar for removal of calcium buildup.
	Drain tubing is clogged.	Clear tubing.
	Drain Clamp hole is misaligned.	Align with hole in the drain pipe.
	Excessive drain flow rate.	Replace Drain Restrictor.
Faucet leaks or drips	Leaks from spout.	Adjust Faucet by turning the tee bar just below the handle to provide a small amount of free play in handle when shut off. O-rings are bad, repair or replace faucet.
	Leaks from base of the delivery tube.	O-ring is bad, replace O-ring.
	Leaks from beneath the handle.	O-rings are bad. Repair or replace the faucet.
Amber light on Water Quality Monitor	System not being used for extended period of time	Empty storage tank. Wait 15 minutes (the system is making water) and test water quality again.
	Filters are plugged or membrane is fouled or exhausted.	Replace filters and/or membrane.
Fitting leaks in general	Close the Feed Water Saddle Valve and relieve pressure before disconnecting any tubing or replacing any fitting. Before replacing a fitting, re-cut the tubing and re-insert into the fitting to see if that solves the leak. If pipe threads are leaking, remove and retape with Teflon tape.	



R.O. DRINKING WATER SYSTEM

FIVE/ONE YEAR LIMITED WARRANTY

Master Water Conditioning warrants its R.O. Drinking Water System to be free from defects in materials and workmanship for a period of five years from the date of purchase when installed and operated within recommended parameters.

Master Water Conditioning will repair or replace at its discretion any defective component. This warranty does not cover the disposable sediment and carbon filters whose service life depends on feed water conditions. The reverse osmosis membrane is warranted for one year. If the required prefilter conditions to the membrane are not followed the membrane will not be warranted.

CONDITIONS OF WARRANTY

The above warranty shall not apply to any part of the Master Water Conditioning R.O. Drinking Water System that is damaged because of occurrences including but not limited to neglect, misuse, alteration, accident, misapplication, physical damage, or damage caused by fire, acts of God, freezing or hot water.

All replacement filters and membranes must be Master Water Conditioning filters and membranes or the warranty is void. If the unit is altered by anyone other than Master Water Conditioning the warranty is void.

To obtain warranty service: (A) contact your local dealer who supplied the unit, or (B) contact the factory for the dealer nearest you. It is the obligation of the owner to pay for shipping or travel charges to return the defective part.

This is the sole warranty made by Master Water Conditioning with respect to the R.O. Drinking Water System. No other warranties, expressed or implied, are given including merchantability or fitness for a particular purpose, incidental or consequential damages, or other losses.

This exclusion applies to the extent exclusion is permitted by the law.

No person or representative is authorized to assume for Master Water Conditioning any liability on its behalf, or in its name, except to refer the purchaser to this warranty.

This warranty gives you specific legal rights, you may also have other rights which vary from state to state.



224 Shoemaker Road • Pottstown, PA 19464

Phone (610) 323-8358

Fax (610) 323-5526

www.masterwater.com